

Exercises on the Magnetic Interaction

Exercise 1.1

Consider two infinitely long conducting wires that are parallel to each other and lie in the x-z plane. The wires are parallel to the z-axis, and are each a distance a away from the z-axis as shown in the figure. The current in the wire that passes through $x = +a$ is flowing out of the page (i.e. in the $+z$ -direction). The current in the wire that passes through $x = -a$ is flowing into the page (i.e. in the $-z$ direction). Determine the net magnetic field for points on the x-axis for values $x > a$.

We are lucky that the wires are of infinite length because the magnetic field they produce is relatively simple. To solve this problem, we can use the result we derived in lecture for the magnetic field produced by an infinitely long wire and the superposition principle. For any location on the x-axis, the net magnetic field is the vector sum of the magnetic field produced by *the wire on the right* plus the magnetic field produced by *the wire on the left*.

The magnitude of the magnetic field \vec{B} produced by an infinitely long wire is $B = \mu_0 I / (2\pi r)$, where r is the perpendicular distance to the wire. The direction of \vec{B} is determined by the right hand rule as discussed in lecture. Let's call the wire on the right "R", and the one on the left "L". Then, for values of $x > a$, the magnetic field at the position $(x, 0, 0)$ caused by the left rod is $\vec{B}_L = \mu_0 I / (2\pi(x+a))(-\hat{j})$. The direction is determined using the right hand rule, and is in the $-y$ direction since the current is flowing into the page and x is to the right of the wire. Similarly, the magnetic field at the position $(x, 0, 0)$ caused by the right rod is $\vec{B}_R = \mu_0 I / (2\pi(x-a))$. In this case, since the current is flowing out of the page, the direction is in the $+y$ direction: $\vec{B}_R = \mu_0 I / (2\pi(x-a))(+\hat{j})$. The net magnetic field is the vector sum of the magnetic fields produced by the two wires:

$$\begin{aligned}\vec{B}_{net} &= \vec{B}_L + \vec{B}_R \\ &= \frac{\mu_0 I}{2\pi(x+a)}(-\hat{j}) + \frac{\mu_0 I}{2\pi(x-a)}(+\hat{j}) \\ &= \frac{\mu_0 I a}{\pi(x^2 - a^2)}\hat{j}\end{aligned}$$

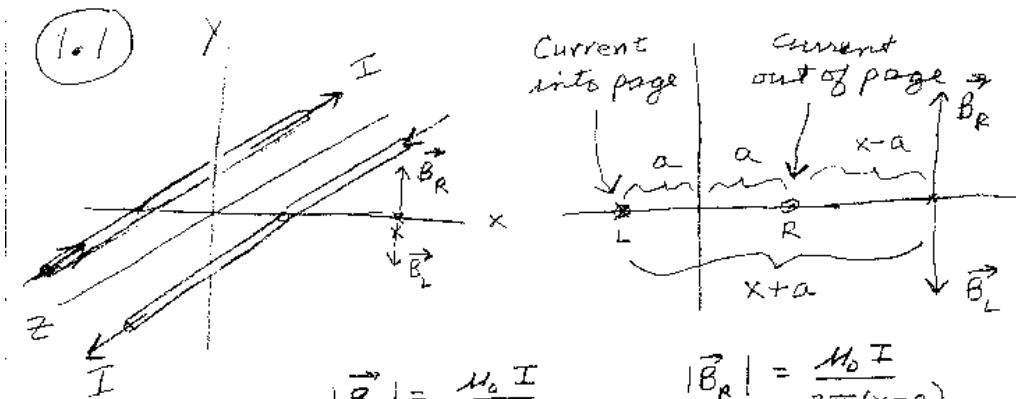

$$|\vec{B}_L| = \frac{\mu_0 I}{2\pi(x+a)} \quad |\vec{B}_R| = \frac{\mu_0 I}{2\pi(x-a)}$$

$$\vec{B}_{NET} = \frac{\mu_0 I}{2\pi(x-a)} (+\hat{j}) + \frac{\mu_0 I}{2\pi(x+a)} (-\hat{j}) = \frac{\mu_0 I a}{\pi(x^2 - a^2)} \hat{j}$$

(1.2)

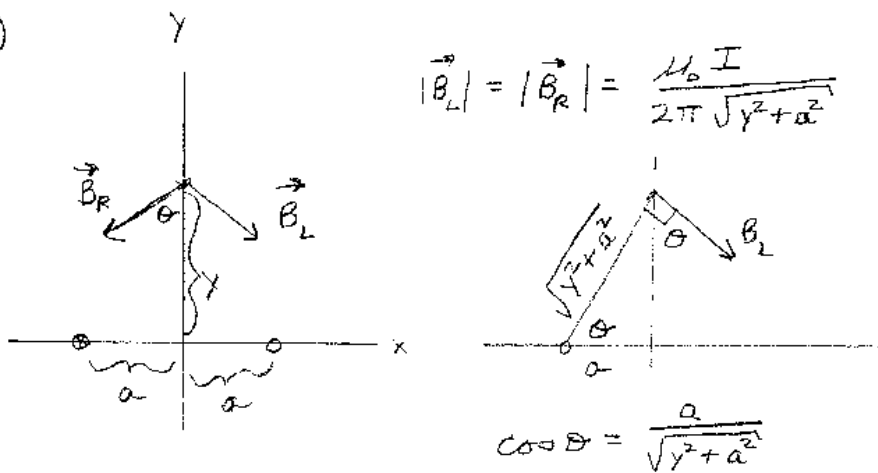

$$|\vec{B}_L| = |\vec{B}_R| = \frac{\mu_0 I}{2\pi\sqrt{y^2 + a^2}}$$

$$\cos \theta = \frac{a}{\sqrt{y^2 + a^2}}$$

$$\vec{B}_{NET} = 2 |\vec{B}_R| \cos \theta (-\hat{j})$$

$$= 2 \frac{\mu_0 I}{2\pi\sqrt{y^2 + a^2}} \frac{a}{\sqrt{y^2 + a^2}} (-\hat{j})$$

Exercise 1.2

Consider the same two wires as in the first exercise above. Find the net magnetic field for locations on the y-axis: $(0, y, 0)$.

To solve for the net magnetic field for positions on the y-axis, we can use the same method as in Exercise 1.1. We first find the magnetic field due to each of the wires, then add the two fields via vector addition.

The magnitude of the magnetic field at $(0, y, 0)$ that is caused by the left wire is $|\vec{B}_L| = \mu_0 I / (2\pi\sqrt{y^2 + a^2})$. The distance $\sqrt{y^2 + a^2}$ is the distance from $(0, y, 0)$ to the wire. The direction of \vec{B}_L at $(0, y, 0)$ is determined by the right hand rule and is indicated by the angle θ in the figure.

The magnitude of the magnetic field at $(0, y, 0)$ that is caused by the right wire is the same as the left wire: $|\vec{B}_R| = \mu_0 I / (2\pi\sqrt{y^2 + a^2})$. However, the direction is on the other side of the y-axis and is indicated in the figure.

When the two vectors are added, the x-components cancel. The surviving y-component is $\vec{B}_{net} = 2|\vec{B}_R|\cos\theta (-\hat{j})$.

$$\begin{aligned}\vec{B}_{net} &= 2|\vec{B}_R|\cos\theta (-\hat{j}) \\ &= 2\frac{\mu_0 I}{2\pi\sqrt{y^2 + a^2}}\cos\theta (-\hat{j}) \\ &= 2\frac{\mu_0 I}{2\pi\sqrt{y^2 + a^2}}\frac{a}{\sqrt{y^2 + a^2}}(-\hat{j})\end{aligned}$$

since $\cos\theta$ is equal to $a/\sqrt{y^2 + a^2}$. Multiplying the terms in the expression yields

$$\vec{B}_{net} = \frac{\mu_0 I a}{\pi(y^2 + a^2)}(-\hat{j}) \quad (1)$$

Note that the magnetic field is a maximum at $y = 0$.

Exercise 1.3

Harriot has a hoola hoop. She charges the circular plastic hoola hoop uniformly with a total charge of Q . She then spins the hoola hoop about its axis with a frequency of f cycles per second. The hoola hoop has a radius of R . Find the strength of the magnetic field at the center of the hoop.

The spinning charged hoola hoop produces a magnet field that is the same as a circular wire that has a current I flowing through it. We need to find an expression for

the current I in terms of the total charge Q on the hoop and its rotational frequency f . In lecture we derived the expression for the magnetic field at the center of a circular wire that has a current I flowing through it:

$$B_{center} = \frac{\mu_0 I}{2R} \quad (2)$$

where B_{center} is the magnitude of the magnetic field at the center. The current I is just the charge flowing past a point in the wire per second, so for the spinning hoop we have $I = Qf$. The current is Qf because every second there are f rotations of the hoop and each rotation brings a charge Q by the point. So the magnitude of the magnetic field at the center of the hoola hoop is

$$B_{center} = \frac{\mu_0 f Q}{2R} \quad (3)$$

This is an example of a magnetic field being produced by a rotating charged object.

Exercise 1.4

Irvin bought an infinitely long copper wire. He bends it to form a 90° angle with the center part a quarter circle of radius R as shown in the figure. Now, he connects the wire to a voltage source (at infinity) so that a steady current I flows in the wire. What is the magnetic field at the center of the quarter circle?

We can divide the wire into three sections: two semi-infinite straight segments and one quarter circle. In the figure, the segments are as follows: a semi-infinite straight wire from ∞ to the point a , a quarter circle from a to b , and a semi-infinite straight wire from b to ∞ . The center of the circle is at one end of the semi-infinite segments. To find the magnetic field at the center of the quarter circle, we can use the principle of superposition. We just need to add the magnetic field due to the three segments. In lecture we calculated the magnetic field from a straight wire segment. For an infinite wire we obtained $B = \mu_0 I / (2\pi d)$, where d is the perpendicular distance to the wire. Here the location is a distance R from a semi-infinite wire. Using the result from lecture we have

$$B = \frac{\mu_0 I}{4\pi R} \quad (4)$$

since the wire is one half of an infinite one and the location is at the end. To find the magnetic field at the center of the quarter circle, we can use the Biot-Savart Law as we did for the full circle. Since the wire is only $1/4$ of a full circle, the magnetic field

1.3

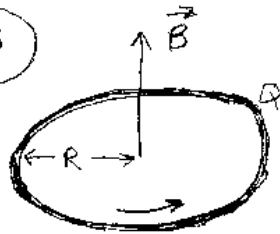

$I = Q f$ the amount of charge passing a point per sec

$$|\vec{B}_{\text{center}}| = \frac{\mu_0 I}{2R} = \boxed{\frac{\mu_0 Q f}{2R}}$$

1.4

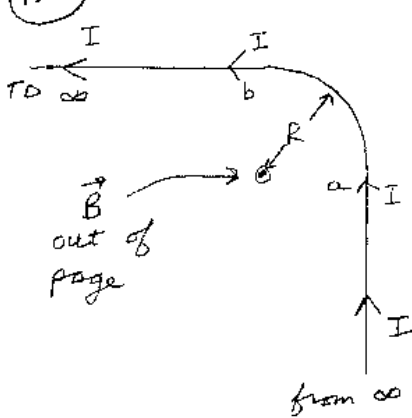

$$\vec{B}_{\text{NET}} = \vec{B}_{\text{from } \infty \text{ to } a} + \vec{B}_{a \rightarrow b} + \vec{B}_{b \text{ to } \infty}$$

$$|\vec{B}_{\text{NET}}| = \frac{\mu_0 I}{4\pi R} + \frac{\mu_0 I}{8R} + \frac{\mu_0 I}{4\pi R}$$

$$= \frac{\mu_0 I}{2R} \left(\frac{1}{\pi} + \frac{1}{4} \right)$$

1.5

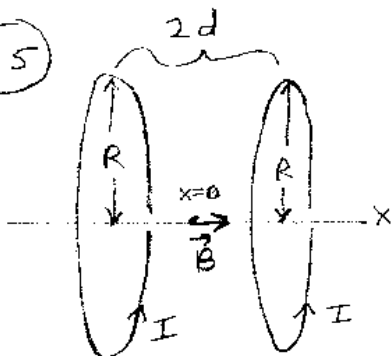

$$B_x = \frac{\mu_0 I}{2(R^2 + (d+x)^2)^{3/2}} + \frac{\mu_0 I}{2(R^2 + (d-x)^2)^{3/2}}$$

is $(1/4)\mu_0 I/(2R) = \mu_0 I/(8R)$. Adding up the magnetic field from the three segments gives:

$$\begin{aligned} |\vec{B}_{net}| &= \frac{\mu_0 I}{4\pi R} + \frac{\mu_0 I}{8R} + \frac{\mu_0 I}{4\pi R} \\ &= \frac{\mu_0 I}{2R} \left(\frac{1}{\pi} + \frac{1}{4} \right) \end{aligned}$$

Exercise 1.5

Helmholz coils are a set of two co-axial circular coils of wire. Let each coil have a radius of R , a current I , and N turns of wire. The coils are separated by a distance $2d$. Let the x-axis lie on the common axis of the coils with $x = 0$ located midway between the coils. Find an expression for the magnetic field on the common axis in terms of x .

We can use the result from lecture for the magnetic field on the axis of a circular loop of wire. For our application the distance from x to the center of the left coil is $d + x$. The distance from x to the center of the right coil is $d - x$. The net magnetic field is the sum of the magnetic fields at x due to each of the coils:

$$\begin{aligned} B_x &= \frac{\mu_0 I R^2}{2(R^2 + (d + x)^2)^{3/2}} + \frac{\mu_0 I R^2}{2(R^2 + (d - x)^2)^{3/2}} \\ B_x &= \frac{\mu_0 I R^2}{2} \left(\frac{1}{(R^2 + (d + x)^2)^{3/2}} + \frac{1}{(R^2 + (d - x)^2)^{3/2}} \right) \end{aligned}$$

What makes Helmholtz coils special is the following: d can be chosen to make the magnetic field nearly constant near the center of the coils. One can determine the best value for d by examining the derivatives of B_x with respect to x at $x = 0$. If one evaluates the first derivative at $x = 0$, the result is

$$\left. \frac{dB_x}{dx} \right|_{x=0} = 0 \quad (5)$$

The first derivative is zero at $x = 0$ for any choice of d . The second derivative is a bit messy to evaluate, but equals

$$\left. \frac{d^2 B_x}{dx^2} \right|_{x=0} = 2R^2 - 8d^2 \quad (6)$$

If $d = R/2$ then the second derivative at $x = 0$ is also zero. With this choice of d the magnetic field near $x = 0$ is nearly constant. When constructing Helmholtz coils, one

usually chooses $d = R/2$ to produce a nearly constant magnetic field in the region of space between the coils. This is why Helmholtz coils are so special.

Exercise 1.6

Reggie is given a rectangular loop of wire and he wants to make a magnetic fields. The rectangle has sides of length $2w$ and $2l$. To make a magnetic field, Reggie hooks up the wire to a battery and a current of magnitude I flows in the wire. Reggie asks us to determine the strength of the magnetic field at the center of the rectangle?

It is fortunate that we are taking Phy133, because in lecture we derived an expression for the strength of the magnetic field produce by a straight piece of wire. The result is

$$B = \frac{\mu_0 I}{4\pi d} \left(\frac{a}{\sqrt{d^2 + a^2}} + \frac{b}{\sqrt{d^2 + b^2}} \right) \quad (7)$$

where d is the perpendicular distance to the straight wire segment. We can apply this result to our rectangle, since each segment is a straight wire. We just need to find the magnetic field at the center due to each of the four sides and add up the fields. **The magnetic field produced by each leg will point out of the page** in the center, so we can just add the magnitudes. For the left side, $d = l$, $a = w$ and $b = w$, so we have

$$\begin{aligned} B_L &= \frac{\mu_0 I}{4\pi l} \left(\frac{w}{\sqrt{l^2 + w^2}} + \frac{w}{\sqrt{l^2 + w^2}} \right) \\ &= \frac{\mu_0 I}{2\pi l} \frac{w}{\sqrt{l^2 + w^2}} \end{aligned}$$

for the magnetic field at the center caused by the wire segment on the left. The magnetic field at the center caused by the wire on the right side will be the same expression, since $d = l$, $a = w$ and $b = w$:

$$B_R = \frac{\mu_0 I}{2\pi l} \frac{w}{\sqrt{l^2 + w^2}} \quad (8)$$

For the magnetic field at the center produced by the top wire we have $d = w$, $a = l$ and $b = l$, so

$$B_T = \frac{\mu_0 I}{4\pi w} \left(\frac{l}{\sqrt{w^2 + l^2}} + \frac{l}{\sqrt{w^2 + l^2}} \right)$$

$$= \frac{\mu_0 I}{2\pi w} \frac{l}{\sqrt{l^2 + w^2}}$$

As before, the magnetic field caused by the bottom leg of the rectangle at the center will be the same as B_T . That is $B_B = B_T$. Adding all four sides together gives the net magnetic field at the center as:

$$\begin{aligned} B_{net} &= \frac{\mu_0 I}{2\pi w} \frac{2l}{\sqrt{l^2 + w^2}} + \frac{\mu_0 I}{2\pi l} \frac{2w}{\sqrt{l^2 + w^2}} \\ &= \frac{\mu_0 I}{\pi \sqrt{l^2 + w^2}} \left(\frac{l}{w} + \frac{w}{l} \right) \\ &= \frac{\mu_0 I \sqrt{l^2 + w^2}}{\pi l w} \end{aligned}$$

In the case of a square loop of wire, $l = w$, and

$$B_{net} = \frac{\mu_0 I \sqrt{2}}{\pi l} \tag{9}$$

at the center of a square loop of wire that carries a current I .

Exercise 1.7

George is riding on a train and he is carrying with him an infinitely long uniformly charged rod. The rod is aligned in the direction that the train is moving. George measures the charge per unit length to be λ . The rod is very thin. His friend Bill is standing on the ground and measures the speed of the train to be v to the right. To him, the charged rod is also moving with a speed v in a direction along its length to the right. What are the electric and magnetic fields that George observes, and what are the electric and magnetic fields that Bill observes?

In George's reference frame (moving train) the charged rod is at rest. Since the rod is not moving, there are no electric currents according to George. In George's reference frame (i.e. if you are sitting in the train) *there is no magnetic field*. The electric field in George's reference frame is that due to a uniformly charge rod. We have solved this problem before using Gauss's Law. We obtained $E = 2k\lambda/r$ where r is the perpendicular distance from the rod.

$$\begin{aligned} B_{George} &= 0 \\ E_{George} &= \frac{2k\lambda}{r} \end{aligned}$$

1.6

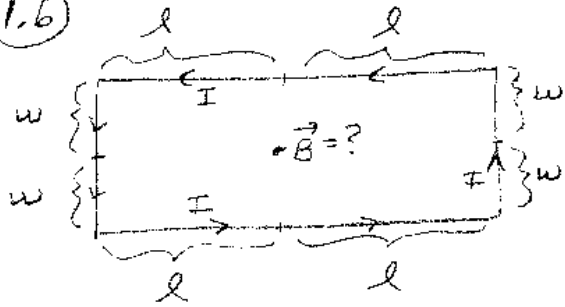

$$\vec{B}_{\text{TOT}} = \vec{B}_L + \vec{B}_R + \vec{B}_T + \vec{B}_B$$

$$|\vec{B}_{\text{TOT}}| = \frac{\mu_0 I}{2\pi l} \frac{w}{\sqrt{l^2+w^2}} + \frac{\mu_0 I}{2\pi l} \frac{w}{\sqrt{l^2+w^2}} + \frac{\mu_0 I}{2\pi w} \frac{l}{\sqrt{l^2+w^2}} + \frac{\mu_0 I}{2\pi w} \frac{l}{\sqrt{l^2+w^2}}$$

$$|\vec{B}_{\text{TOT}}| = \frac{\mu_0 I \sqrt{l^2+w^2}}{\pi l w}$$

1.7



Bill (rod moving)

George (rod at rest)

1.8

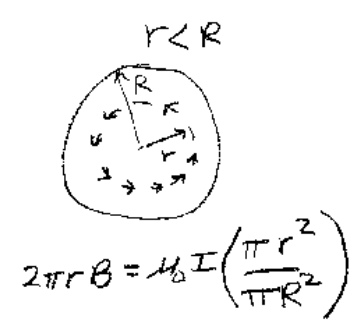
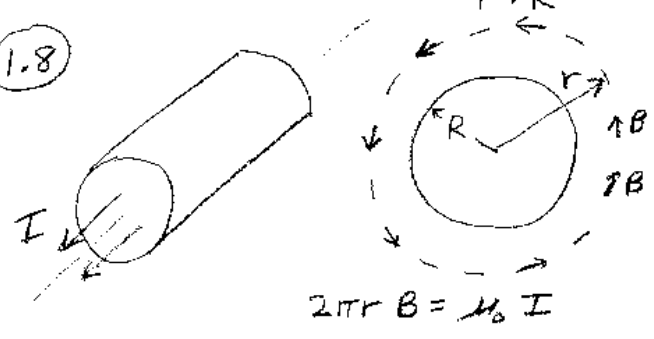

where the direction of \vec{E} is radially away from the rod.

In Bill's reference frame (standing on the ground) the rod is moving with a speed v to the right. The moving rod produces a current. If we assume that the linear charge density of the rod is also λ according to Bill, then the current is just $I = \lambda v$. This is true, because in one second the rod has moved a distance of v and thus λv amount of charge has passed a point. The moving rod acts as an infinitely long wire carrying a current $I = \lambda v$. So the magnetic field that Bill measures is $B_{Bill} = \mu_0 \lambda v / (2\pi r)$ where r is the radial distance from the rod. Since the rod also has a net charge according to Bill, Bill will also experience an electric field which is produced from an infinite charged rod:

$$\begin{aligned} B_{Bill} &= \frac{\mu_0 \lambda v}{2\pi r} \\ E_{Bill} &= \frac{2k\lambda}{r} \end{aligned}$$

Bill will say there is a magnetic field, George will say there is not. They are both correct. Since a source for magnetic fields is moving charge, and velocity is a relative quantity, magnetic fields are a relative quantity. That is, the magnetic field depends on the observers reference frame. In our calculation we obtain the same electric field for both Bill and George. However, this is not correct. We have calculated E and B correctly for George, but we have not calculated B or E correctly for Bill. Einstein's Theory of Special Relativity is needed to solve the problem correctly. We cover this topic in the next Physics course, Phy234.

Exercise 1.8

You have an infinitely long straight cylindrical wire that has a radius of R . The wire has a uniform current density flowing through it. Let the current flowing in the wire be I . Find an expression for the magnetic field inside and outside the wire.

Because there is cylindrical symmetry in the current distribution, we might be able to use Ampere's Law to assist in determining the magnetic field. To use Ampere's Law, we need to find a path for which $\oint \vec{B} \cdot d\vec{r}$ is easy to calculate. Because the wire is infinitely long and has axial symmetry about the axis, **the strength of the magnetic field can only depend on r** , the radial distance from the axis. We can also make the argument that the direction of \vec{B} must be circular. That is, \vec{B} must be perpendicular to \vec{r} and the direction of I , where \vec{r} is the radial vector from the axis to the location of the magnetic field.

The arguments go as follows. \vec{B} cannot point radially away from the axis because there are no static sources for magnetic fields. Magnetic field cannot emanate from a point or line. \vec{B} cannot point in the direction of I because if it did, by Ampere's Law, the field in this direction would be constant everywhere. Thus, the magnetic field is "circular" around the axis. The best path to choose is a circular path such that the center of the circle is on the axis and the plane of the circle is perpendicular to the axis. With this choice, $|\vec{B}|$ is a constant along the path and $\oint \vec{B} \cdot d\vec{r} = 2\pi r |\vec{B}|$ where r is the radius of the path.

Case 1: outside the wire, $r > R$:

In this case all the current passes through the circular path.

$$\begin{aligned}\oint \vec{B} \cdot d\vec{r} &= \mu_0 I_{\text{through path}} \\ 2\pi r |\vec{B}| &= \mu_0 I \\ |\vec{B}| &= \frac{\mu_0 I}{2\pi r}\end{aligned}$$

Case 2: inside the wire, $r < R$:

In this case only part of the current passes through the circular path. We need to determine how much current passes through a circle of radius r centered on the axis. The amount of current is I times the ratio of the area of the circle to the cross sectional area of the wire: $I(\pi r^2)/(\pi R^2)$. Ampere's Law becomes

$$\begin{aligned}\oint \vec{B} \cdot d\vec{r} &= \mu_0 I_{\text{through path}} \\ 2\pi r |\vec{B}| &= \mu_0 I \frac{\pi r^2}{\pi R^2} \\ |\vec{B}| &= \frac{\mu_0 I r}{2\pi R^2}\end{aligned}$$

So we see that inside the wire the magnet field strength increases linearly with distance from the axis until the wires edge. Outside the wire the magnetic field strength decreases inversely with distance ($1/r$) as if the wire were infinitely thin.

Exercise 2.1

An electron is moving in a region where there is a constant magnetic field. The magnetic field is in the x-direction with magnitude B_0 : $\vec{B} = B_0 \hat{i}$. At a particular moment,

the electron has a velocity in the y -direction with speed v_0 : $\vec{v} = v_0\hat{j}$. At this moment, what magnetic force does the electron feel? Express your answer in terms of B_0 , v_0 and e , the magnitude of the charge on the electron. All three of these variables are greater than zero.

The magnetic force \vec{F}_m on a particle depends on its charge, its velocity and the magnetic field it experiences: $\vec{F}_m = q\vec{v} \times \vec{B}$. By the right-hand rule for the cross product, $\vec{v} \times \vec{B}$ points in the $-z$ direction or the $-\hat{k}$ direction. Since the charge on the electron is negative, the force it feels in this case will be in the $+z$ direction. The magnitude of the force will be ev_0B_0 , so

$$\vec{F}_m = ev_0B_0\hat{k} \quad (10)$$

for the magnetic force that the electron will feel at this particular moment. One could also solve the problem by just carrying out the cross product:

$$\begin{aligned} \vec{F}_m &= -e(\vec{v} \times \vec{B}) \\ &= -e \begin{vmatrix} \hat{i} & \hat{j} & \hat{k} \\ 0 & v_0 & 0 \\ B_0 & 0 & 0 \end{vmatrix} \\ &= -e(-v_0B_0\hat{k}) \\ \vec{F}_m &= ev_0B_0\hat{k} \end{aligned}$$

Note that if the particle were a proton instead of an electron, the force it would feel would be opposite to that of the electron. In this case, $\vec{F}_m = -ev_0B_0\hat{k}$ since the charge on the proton has the same magnitude but is opposite in sign to that of the electron.

Exercise 2.2

In the figure, we are told that the magnetic field is perpendicular to the page. However, we don't know if it points into or out of the page. The trajectory labeled ${}_1e$ is that of an electron moving in the direction of the arrow. What is the direction of the magnetic field, and what is the sign of the charge on the second particle moving in the field?

By looking at the curvature of the trajectory of the electron, we can see that the force that the electron feels is towards the upper left corner of the diagram. Since

2.1

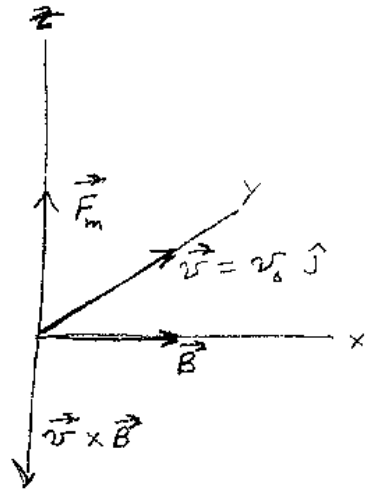

$$\begin{aligned} \vec{F}_m &= -e(v_0 \hat{j} \times B_0 \hat{i}) \\ &= e v_0 B_0 (\hat{i} \times \hat{j}) \\ &= e v_0 B_0 \hat{k} \end{aligned}$$

2.2

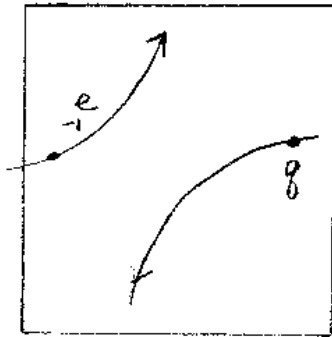

$$\begin{aligned} \vec{B} &=? \\ \vec{v} &=? \end{aligned}$$

2.3

$$e v_{\perp} B_0 = \frac{m v_{\perp}^2}{r}$$

$$r = \frac{m v_{\perp}}{e B_0}$$

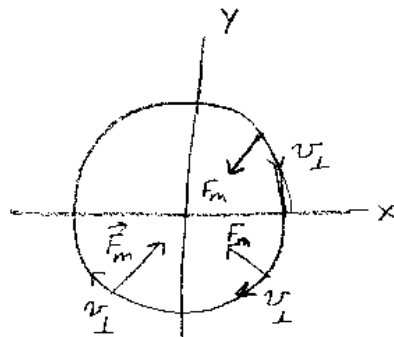
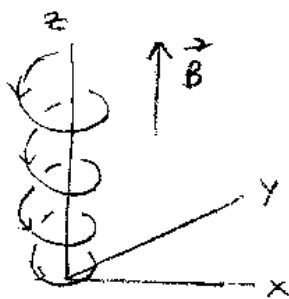

the charge of the electron is negative, this means that $\vec{v} \times \vec{B}$ for the electron must point towards the lower right corner of the diagram. Since \vec{v} is towards the upper right corner of the diagram, the direction of \vec{B} must be **out of the page**.

By looking at the curvature of the trajectory of the other particle, we can see that the force it feels is towards the lower right of the diagram. Since \vec{B} is out of the page, $\vec{v} \times \vec{B}$ points towards the upper left corner of the diagram. Since the force is in the opposite direction, the second particle has a **negative** charge.

Exercise 2.3

In a certain region of space, there exists a constant magnetic field of magnitude B_0 . We align our coordinate system so the magnetic field points in the z -direction: $\vec{B} = B_0\hat{k}$. A proton is thrown into this region with an initial velocity of \vec{v}_0 . What will the trajectory of the proton be? That is, describe the motion of the proton. There is no electric field in the region.

Since there is no electric field, the only force the proton will feel is the magnetic force. The magnetic force depends on the protons velocity. If there is no velocity, there is no force. So lets assume the proton has a velocity $\vec{v} = v_x\hat{i} + v_y\hat{j} + v_z\hat{k}$ and find the force it feels with this velocity. The magnetic force on a particle with charge $+e$ is $\vec{F}_m = e(\vec{v} \times \vec{B})$. Since $\vec{B} = B_0\hat{k}$, the force on the proton is

$$\begin{aligned}\vec{F}_m &= e(\vec{v} \times \vec{B}) \\ &= e \begin{vmatrix} \hat{i} & \hat{j} & \hat{k} \\ v_x & v_y & v_z \\ 0 & 0 & B_0 \end{vmatrix} \\ &= e(v_y B_0 \hat{i} - v_x B_0 \hat{j}) \\ \vec{F}_m &= eB_0(v_y \hat{i} - v_x \hat{j})\end{aligned}$$

This force is fairly simple. Note that **there is no force in the z -direction**. This is the direction of the magnetic field. Since the force equals the vector cross product between \vec{v} and \vec{B} there can be no component of \vec{F}_m in either the \vec{B} direction or the \vec{v} direction. If the proton has an initial component of velocity in the direction of the magnetic field, this component of the velocity will not change in time. In our case this means that $v_z = \text{constant} = v_{z0}$, the initial value of v_z .

Only the velocity components in the x - y plane change their values, since the force is only in the x - y plane. Let $\vec{v}_\perp = v_x\hat{i} + v_y\hat{j}$, the velocity in the x - y plane. From the expression for the force above, we notice that $\vec{F}_m \cdot \vec{v} = eB_0(v_y v_x - v_x v_y) = 0$. The

magnetic force is always perpendicular to the velocity and \vec{v}_\perp . So the velocity in the x-y plane \vec{v}_\perp does not change in magnitude, but only in the direction perpendicular to itself. The magnitude of the force on the particle is

$$\begin{aligned} |\vec{F}_m| &= eB_0|(v_y\hat{i} - v_x\hat{j})| \\ &= eB_0\sqrt{v_y^2 - v_x^2} \\ &= eB_0|v_\perp| \end{aligned}$$

and directed perpendicular to \vec{v}_\perp . This type of force produces circular motion, whose acceleration is v_\perp^2/r , where r is the radius of the circle. From $\vec{F}_m = m\vec{a}$ we obtain

$$\begin{aligned} eB_0|v_\perp| &= m\frac{v_\perp^2}{r} \\ r &= \frac{m|v_\perp|}{eB_0} \end{aligned}$$

for the radius of the circle. Thus, when a proton is thrown into a region of space that has a constant magnetic field, it will travel in a circle in the plane perpendicular to the magnetic field. This circular motion will be superimposed with one of constant velocity in the direction of the magnetic field (the z-direction in our case). The combined motion will be a helix.

Exercise 2.4

Suppose in Exercise 2.3 the initial velocity of the proton is $v_0\hat{i}$, that is a speed of v_0 in the x-direction. The magnetic field is constant and equal to $B_0\hat{k}$. As described in the last problem, the proton will travel in a circle. Find an expression for the number of revolutions/sec (i.e. the frequency) that the proton makes in its circular motion.

As derived in the last problem, equating the net force to the product of mass and acceleration yields

$$\begin{aligned} |\vec{F}_m| &= m\frac{v_0^2}{r} \\ eB_0|v_0| &= m\frac{v_0^2}{r} \\ r &= \frac{mv_0}{eB_0} \end{aligned}$$

2.4

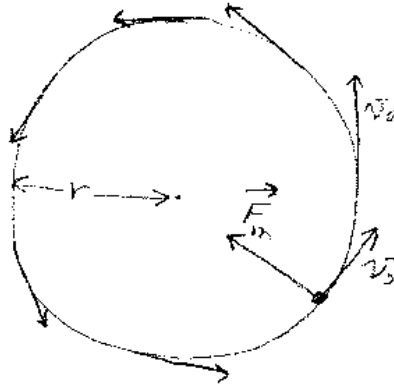

$$|\vec{F}_m| = e B_0 v_0$$

$$e B_0 v_0 = m \frac{v_0^2}{r}$$

$$r = \frac{m v_0}{e B_0}$$

$$T = \text{time to travel around the circle} = \frac{2\pi r}{v_0} = \frac{2\pi m v_0}{e B_0 v_0} = \frac{2\pi m}{e B_0}$$

$$f = \frac{1}{T} = \frac{e B_0}{2\pi m}$$

2.5

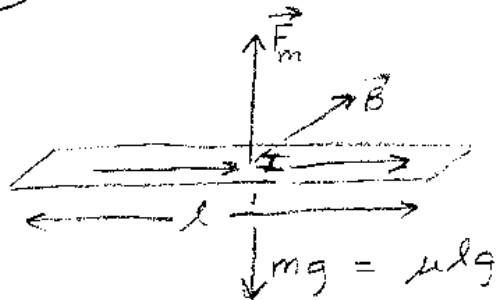

$$|\vec{F}_m| = l I B$$

$$l I_{\min} B = \mu l g$$

$$I_{\min} = \frac{\mu g}{B}$$

for the radius of the circle. The number of revolutions/sec is the distance traveled in one second divided by the circumference of the circle. In one second the distance traveled is v_0 , we we have for the frequency f of the motion

$$\begin{aligned} f &= \frac{v_0}{2\pi r} \\ &= \frac{eB_0}{2\pi m} \end{aligned}$$

The proton will make $eB_0/(2\pi m)$ revolutions per second. The amazing thing about this result is that v_0 doesn't enter in the expression for f . The radius r is proportional to v_0 ! If the speed doubles, so will the radius of the circle and hence the time to complete one revolution won't change. The cyclotron, which was the first particle accelerator was based on this principle. The frequency f is called the cyclotron frequency.

Exercise 2.5

In lecture we demonstrated the "levitating foil". A magnetic field of magnitude B was placed perpendicular to a strip of aluminum foil. A current I was made to flow through the foil and the foil rose. If the mass per length of the foil is μ , what minimum current is necessary to make the foil "levitate"?

Consider a length l of the foil. The magnetic force on this piece of foil (i.e. of length l) is $F_m = BIl$, where B is the strength of the magnetic field. To levitate, this force must overcome the gravitational force on the piece. That is, we must have

$$BIl > mg \tag{11}$$

for the foil to levitate. If μ is the mass/length, then the mass of the foil is $m = \mu l$. Thus we see that

$$\begin{aligned} BI_{min}l &= \mu l g \\ I_{min} &= \frac{\mu g}{B} \end{aligned}$$

is the minimum current required for the magnetic force to overcome the weight of the foil.

Exercise 2.6

You have a wire that is bent into the shape of a rectangle with sides a and b . Let

the area vector \vec{A} for the rectangle have a magnitude of $|\vec{A}| = ab$ and a direction perpendicular to the surface of the rectangle. The rectangular wire is placed in a magnetic field \vec{B} , which points upward as shown in the figure. The wire is oriented such that side b is perpendicular to the direction of \vec{B} and the area vector \vec{A} makes an angle θ with respect to the direction of \vec{B} . If a current I flows in the wire, what are the forces on the rectangular wire?

The force on the sides of the wire of length b are shown in the figure. The force on the top side is $\vec{F}_m = I\vec{b} \times \vec{B}$. Since the current in side b (top) is into the page and \vec{B} is directed up, the force is IbB to the right. The force on the bottom side (b) will be in the opposite direction since the current is out of the page. The force on side b (bottom) is IbB but directed to the left. The forces on the sides of length a will be into and out of the page, and they will cancel. Thus, the net force on the rectangular wire is zero. However, there will be a twisting force (torque) as seen in the figure tending to twist the rectangle clockwise.

From your Phy131 class you remember that the torque τ is $\vec{r} \times \vec{F}$. In our case, the torque about the center of side a due to the force on side b (top) is $|\tau| = (a/2)(IbB)\sin\theta$. The moment arm is $a/2$, the force is IbB , and the angle between the force and side a is θ . In this case, the twist is clockwise. Similarly, for the side b (bottom) the torque about the center of side a is $|\tau| = (a/2)(IbB)\sin\theta$. Adding up these two torque contributions gives the total or net torque:

$$|\tau_{net}| = IabB \sin\theta \quad (12)$$

with a clockwise twist. This twist causes the wire to rotate clockwise about an axis through the middle of side a . If the direction of the current is changed properly, the wire will keep rotating and one will have an electric motor.

One can write the expression for the torque in a more succinct way. We can define a vector \vec{m} to be $\vec{m} = I\vec{A}$. Note that $|\vec{m}| = Iab$ and points in a direction normal to the plane of the rectangular wire. For a clockwise twist, the torque vector will point into the page (by the right hand rule). So we can write the vector torque as $\vec{\tau}_{net} = \vec{m} \times \vec{B}$. The vector \vec{m} is called the magnetic moment vector for the wire loop.

Exercise 2.7

Two infinitely long wires are placed parallel to each other and are separated by a distance d . The left wire is labeled "1", and the right wire is labeled "2". The wire on the left has a current of I_1 , and the wire on the right has a current of I_2 . The

2.6

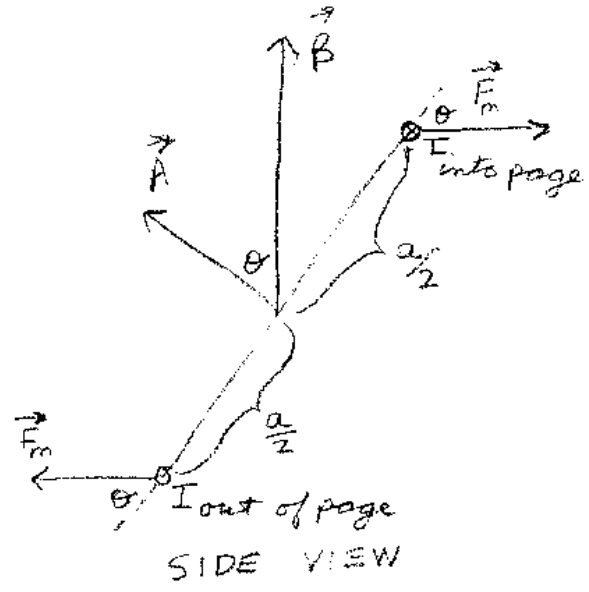
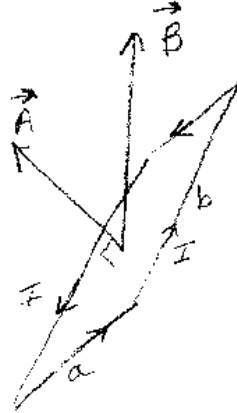

$$|\vec{F}_m| = I b B$$

$$|\vec{\tau}| = \frac{a}{2} |\vec{F}_m| \sin\theta + \frac{a}{2} |\vec{F}_m| \sin\theta$$

$$= a |\vec{F}_m| \sin\theta$$

$$|\vec{\tau}| = a I b B \sin\theta$$

$$\vec{\tau} = I \vec{A} \times \vec{B}$$

$$\vec{\tau} = \vec{m} \times \vec{B}$$

where $\vec{m} \equiv I \vec{A}$

currents in the wires flow in the same direction. What is the magnetic force per length l on wire "2" due to wire "1"?

To find the magnetic force on wire "2" we need to find the magnetic field that it experiences that is produced by wire "1". The magnetic field produced by wire "1" is circular with a magnitude of

$$|\vec{B}| = \frac{\mu_0 I_1}{2\pi d} \quad (13)$$

where d is the distance from the wire. Wire "2" experiences this magnetic field, and it is perpendicular to wire "2" directed downward. So the force on a piece of length l of wire "2" is

$$\begin{aligned} |\vec{F}| &= I_2 l B \\ &= I_2 l \frac{\mu_0 I_1}{2\pi d} \\ &= \frac{\mu_0 I_1 I_2 l}{2\pi d} \end{aligned}$$

By the right-hand-rule, the force on wire "2" is directed toward wire "1".

Exercise 2.8

A piece of curved wire is located in a region of space where **the magnetic field is constant**. The wire starts at the location labeled "a" and ends at the location labeled "b" in the figure. If a current of magnitude I flows in the wire, find an expression for the net force on the wire.

To find the net force on the wire, we need to divide it up into small segments. Then, we find the force on each small segment, and add these forces up via vector addition. So, let's begin. Divide the wire into N small segments and label each segment by an integer: 1,2,3, etc. Call the vector for the i 'th segment $\vec{\Delta}l_i$. The force $\Delta\vec{F}_i$ on the i 'th segment is

$$\Delta\vec{F}_i = I(\vec{\Delta}l_i \times \vec{B}) \quad (14)$$

To find the net force, we just add the $\Delta\vec{F}_i$:

$$\vec{F}_{net} = \sum \Delta\vec{F}_i$$

2.7

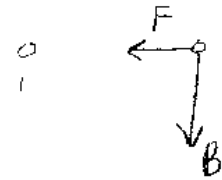
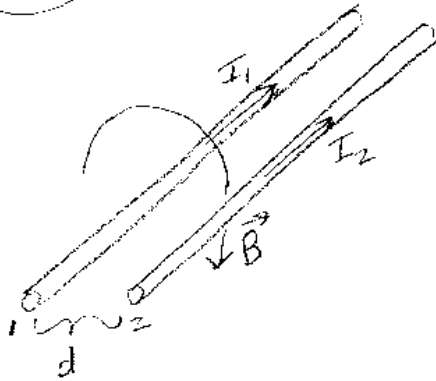

end view

$$B_{\text{at wire 2}} = \frac{\mu_0 I_1}{2\pi d}$$

$$F = l I_2 B$$

$$F = \frac{\mu_0 l I_1 I_2}{2\pi d}$$

2.8

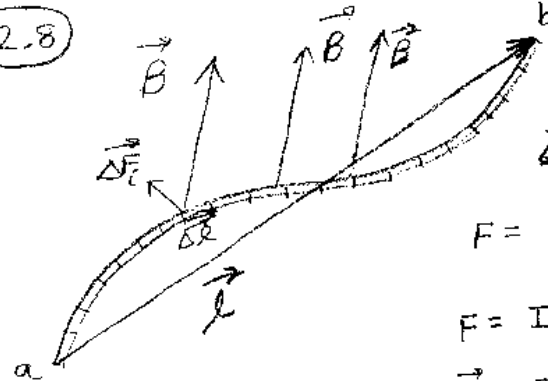

$$\Delta \vec{F}_i = I (\Delta \vec{l}_i \times \vec{B})$$

$$F = \sum_i I (\Delta \vec{l}_i \times \vec{B})$$

$$F = I (\sum_i \Delta \vec{l}_i) \times \vec{B}$$

$$\vec{F} = I \vec{l} \times \vec{B}$$

$$\begin{aligned} &= \sum I(\vec{\Delta}l_i \times \vec{B}) \\ &= I(\sum \vec{\Delta}l_i) \times \vec{B} \end{aligned}$$

We can factor out \vec{B} since **the magnetic field all along the wire is constant**. The sum is easy to evaluate, since it is just the vector sum of all the wire segments. The vector sum is just a vector from "a" to "b".

$$\begin{aligned} \vec{F}_{net} &= I(\sum \vec{\Delta}l_i) \times \vec{B} \\ &= I(\vec{l} \times \vec{B}) \end{aligned}$$

where \vec{l} is a vector from location "a" to "b". This is a very nice result. Note that if the wire is closed, that the net force on it due to a constant magnetic field is zero.