



**California State Polytechnic University, Pomona  
Degree Curriculum Sheet**

Plan (Major) **MANUFACTURING ENGINEERING**

Catalog Year **2007-2008**

Name \_\_\_\_\_

Evaluator \_\_\_\_\_

Subplan/Option \_\_\_\_\_

Minimum Units Required **198**

Student ID \_\_\_\_\_

GWT Satisfied \_\_\_\_\_ Yes \_\_\_\_\_ No

Required Core Courses		
Course		Units
<i>Students in this major are expected to maintain a GPA of at least 2.00 in all core courses.</i>		
Industrial & Manuf Engr Fundamentals	IME 112	3
Industrial & Manuf Engr Computations/Lab	IME 113/L	3
Industrial Costs & Control	IME 239	3
Applications of Statistics	IME 301	3
Engineering Probability and Statistics	IME 312	3
Production Planning & Control	IME 326	3
Facilities Planning & Layout Design/Lab	IME 331/L	4
Quality Control by Statistical Methods/Lab	IME 415/L	4
Senior Project	IME 471 or IME 461	2
Senior Project	IME 472 or IME 462	3
Engineering Graphics I	MFE 126/L	3
Manufacturing Processes - Materials, Metrology & Treatment/Lab	MFE 217/L	3
Manufacturing Processes I - Material Removal/Lab	MFE 221/L	3
Engineering Graphics II/Lab	MFE 226/L	3
Manufacturing Processes II - Form, Cast, Join/Lab	MFE 230/L	3
Measurement & Methods/Lab	MFE 320/L	4
Production Engineering/Lab	MFE 326/L	3
Principles of Numerical Control/Lab	MFE 250/L	3
CAD/CAM/Lab	MFE 375/L	4
Introduction to Computer Integrated Mfg/Lab	MFE 450/L	4
Metal Work Theory & Application	MFE 465	3
Advanced Computer Aided Mfg Systems/Lab	MFE 476/L	4
Discrete Systems Simulation/Lab	IE 429/L	4
<b>Total Units</b>		<b>75</b>

Elective Core Courses	
Course	Units
Manufacturing Electives (Select with advisor approval)	3-4
<b>Total Units</b>	<b>3-4</b>

Required Support Courses			IGE (G.E. Alternative)	
Course		Units		
General Chemistry	CHM 121	3	IGE 120	4
General Chemistry Lab (B2)	CHM 121L	1	IGE 121	4
General Chemistry/Lab	CHM 122/L	4	IGE 122	4
Elements of Electrical Engineering/Lab	ECE 231/L	4	IGE 220	4
Senior Project Seminar	IME 460	1	IGE 221	4
Analytic Geometry/Calculus I (B1)	MAT 114	4	IGE 222	4
Analytic Geometry/Calculus II	MAT 115	4	IGE 223	4
Analytic Geometry/Calculus III	MAT 116	4	or EC 201	
Calculus of Several Variables I	MAT 214	3	or EC 202	
Calculus of Several Variables II	MAT 215	3	IGE 224	4
Elem Linear Algebra and Diff Equations	MAT 224	4	Area A2	4
Vector Statics	ME 214	3	Area A3	4
Vector Dynamics	ME 215	4	Area B	16
Strength Materials	ME 218	3	Area C1, C2,	
Fluid Mechanics	ME 311	3	or C3	4
or Thermodynamics	ME 301	(4)	Area C4	4
General Physics/Lab (B2)	PHY 131/L	4	Area D4	4
General Physics/Lab	PHY 132/L	4		
General Physics/Lab	PHY 133/L	4	See University	
Ethical Cons. in Tech. & Appl Science (C4)	EGR 402	4	Catalog for	
Principles of Economics (D2)	EC 201 or 202	4	information on	
Asset Alloc in Tech Decision Making (D4)	EGR 403	4	how IGE meets	
			G.E. require-	
			ments.	
<b>Total Units</b>		<b>72-73</b>		

General Education Requirements	
Area	Units
<b>Area A Communication &amp; Critical Thinking</b>	<b>12</b>
1 Written Communication	
2 Oral Communication	
3 Critical Thinking	
<b>Area B Mathematics &amp; Natural Sciences</b>	<b>16</b>
<i>Select at least one lab course from sub-area 2 or 3.</i>	
1 Math/Quantitative Reasoning	
2 Physical Science	
3 Biological Science	
4 Science & Technology Synthesis	
<b>Area C Humanities</b>	<b>16</b>
1 Fine and Performing Arts	
2 Philosophy and Civilization	
3 Literature and Foreign Language	
4 Humanities Synthesis	
<b>Area D Social Sciences</b>	<b>20</b>
1 U.S. History, Constitution, American Ideals	
2 History, Economics and Political Science	
3 Sociology, Anthropology, Ethnic & Gender Studies	
4 Social Synthesis	
<b>Total Units</b>	<b>68</b>

American Institutions	
Courses that satisfy this requirement may also satisfy G.E. Areas D1.a and D1.b	8

American Cultural Perspectives Requirement	
Refer to catalog for list of courses that satisfy this requirement. Course may also satisfy major, minor, GE, or unrestricted elective requirements.	4

The following required support courses should be taken to satisfy the indicated GE Requirements to achieve the minimum units to degree listed at the top of this sheet.

Course		GE Area
Analytic Geometry/Calculus I	MAT 114	B1
General Physics/Lab	PHY 131/L	B2
General Chemistry Lab	CHM 121L	B2
Ethical Considerations in Tech. & Appl Science	EGR 402	C4
Principles of Economics	EC 201 or 202	D2
Asset Alloc in Tech Decision Making	EGR 403	D4

The remaining GE requirements may be satisfied by any course approved for that area.

**MANUFACTURING ENGINEERING**

Name \_\_\_\_\_

2007-2008

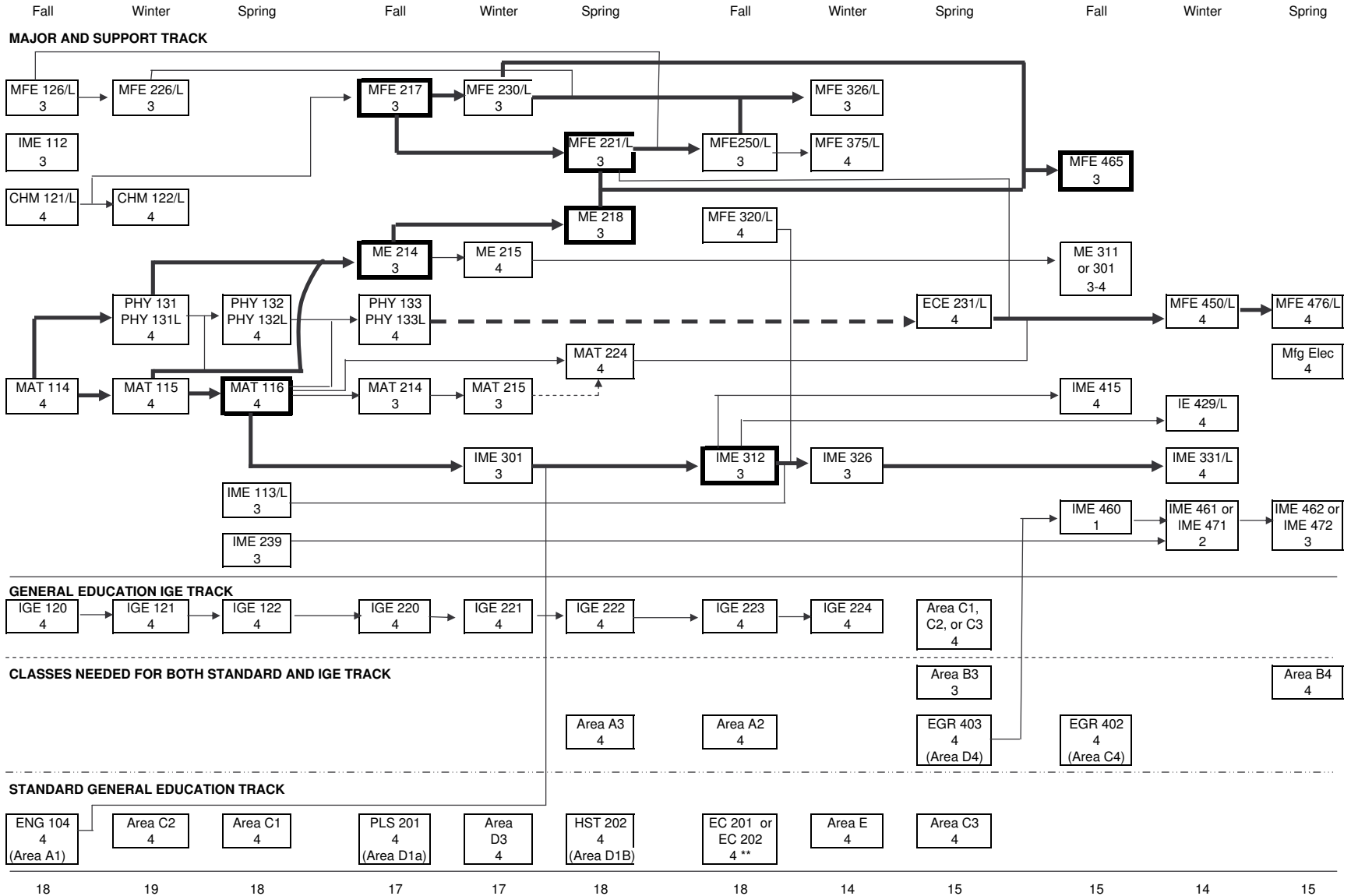

Notes: Important Deadlines:  
 GWT Must be taken by  
 Evaluation must be done by  
 Apply to graduation by

To optimize time here select the classes with bold squares as soon as possible and follow the bold paths.  
 Try to balance workload to the level of units you can handle per quarter, and in the proper mix of difficulty for you.  
 In general, try to take only one MATH or ME course at a time

**THE COURSES LISTED ABOVE INDICATE INTENT OF OFFERING QUARTER, ACTUAL OFFERINGS MAY VARY**

Total Units: 198

Students in the IGE general education program take all classes above this line -----

Students in the Standard general education program take all classes below this line -----

Arrows indicate prerequisites, dashed lines indicate recommended sequences

It is recommended that students take companion activities for ME 214 and ME 215

Note that most MFE courses and many IME courses are offered only once a year

\*\* Note: Students with GE certification or in GE track have already satisfied this requirement

**Industrial and Manufacturing Engineering Department**  
**Manufacturing Engineering Major**  
**Curriculum Year: 2007-2008**

*Your department has developed this road plan, taking into account prerequisites and schedule restrictions.  
You should pay attention to these concerns when deviating from this plan.*

Year 1	Fall	Units	Winter	Units	Spring	Units	Comment
	<b>MFE 126/126L</b> Major Support	3	<b>CHM 122/122L</b> Major Support	4	<b>IME 239</b> Major Core	3	<i>Students in this major are expected to maintain a GPA of at least 2.00 in all core courses.</i>
	<b>IME 112</b> Major Core	3	<b>MAT 115</b> Major Support	4	<b>IME 113/113L</b> Major Core	3	
	<b>CHM 121/121L</b> Major Support	4	<b>PHY 131/131L</b> GE Area B2	4	<b>MAT 116</b> Major Support	4	
	<b>MAT 114</b> GE Area B1	4	<b>GE Area</b> Any approved course in area A2-3, B3, C1-3, D3, or E	4	<b>PHY 132L</b> GE Area B2	1	<i>One course must be completed in each of the GE areas A2-3, B1-3, C1-3, D3, and E.</i>
					<b>PHY 132</b> Major Support	3	
	<b>ENG 104</b> GE Area A1	4			<b>HST 202</b> GE Area D1b	4	
<b>Total Units</b>	<b>18</b>	<b>Total Units</b>	<b>16</b>	<b>Total Units</b>	<b>18</b>		
<b>Total Units for Year</b>					<b>52</b>		

Year 2	Fall	Units	Winter	Units	Spring	Units	Comment
	<b>MFE 217/217L</b> Major Core	3	<b>MFE 230/230L</b> Major Core	3	<b>MFE 221/221L</b> Major Core	3	
	<b>MAT 214</b> Major Support	3	<b>MAT 215</b> Major Support	3	<b>ME 218</b> Major Support	3	
	<b>ME 214</b> Major Support	3	<b>MFE 226/226L</b> Major Core	3	<b>MAT 216</b> Major Support	4	
	<b>PHY 133/133L</b> Major Support	4	<b>IME 301</b> Major Core	3	<b>GE Area</b> Any approved course in area A2-3, B3, C1-3, D3, or E	4	
			<b>ME 215</b> Major Support	4			
<b>Total Units</b>	<b>13</b>	<b>Total Units</b>	<b>16</b>	<b>Total Units</b>	<b>14</b>		
<b>Total Units for Year</b>					<b>43</b>		

Year 3	Fall	Units	Winter	Units	Spring	Units	Comment	
	<b>IME 312</b> Major Support	3	<b>IME 326</b> Major Core	3	<b>IME 331/331L</b> Major Core	4		
	<b>ECE 231/251L</b> Major Support	4	<b>MFE 320/320L</b> Major Core	4	<b>GE Area</b> Any approved course in area A2-3, B3, C1-3, D3, or E	4		
	<b>MFE 250/250L</b> Major Core	3	<b>MFE 326/326L</b> Major Core	3	<b>GE Area</b> Any approved course in area A2-3, B3, C1-3, D3, or E	4		
	<b>PLS 201</b> GE Area D1a	4	<b>EC 201 or 202</b> GE Area D2	4	<b>EGR 403</b> GE Area D4	4		
	<b>GE Area</b> Any approved course in area A2-3, B3, C1-3, D3, or E	4	<b>GE Area</b> Any approved course in area A2-3, B3, C1-3, D3, or E	4				
	<i>Take the Graduation Writing Test</i>							
	<b>Total Units</b>	<b>18</b>	<b>Total Units</b>	<b>18</b>	<b>Total Units</b>	<b>16</b>		
					<b>Total Units for Year</b>	<b>52</b>		

Year 4	Fall	Units	Winter	Units	Spring	Units	Comment
	<b>MFE 465</b> Major Core	3	<b>MFE 375/375L</b> Major Core	4	<b>IME 415/415L</b> Major Core	4	<i>Department approval required for selection of GE Synthesis Area B4.</i>
	<b>IME 460</b> Major Support	1	<b>MFE 450/450L</b> Major Core	4	<b>IME 472 or IME 462</b> Major Core	3	
	<b>ME 311 or 301</b> Major Support	3	<b>Mfg Elective</b> Major Core	3	<b>MFE 476/476L</b> Major Core	4	<i>All GE Area A courses and all lower division GE courses in a GE area must be completed before taking the GE Synthesis course in that area.</i>
	<b>GE Area</b> Any approved course in area A2-3, B3, C1-3, D3, or E	4	<b>IME 471 or IME 461</b> Major Core	2	<b>IE 429/429L</b> Major Core	4	
	<b>GE Synthesis</b> GE Area B4	4	<b>EGR 402</b> GE Area C4	4	<b>GE Area</b> Any approved course in area A2-3, B3, C1-3, D3, or E	4	<i>Manufacturing Electives must be selected with advisor approval.</i>
			<i>Request a graduation check</i>		<i>File an application for graduation</i>		
	<b>Total Units</b>	<b>15</b>	<b>Total Units</b>	<b>17</b>	<b>Total Units</b>	<b>19</b>	
					<b>Total Units for Year</b>	<b>51</b>	

<b>Total Units on Plan</b>	<b>198</b>
<b>Major Core Units</b>	<b>75-76</b>
<b>Major Support Units</b>	<b>54-55</b>
<b>General Education Units</b>	<b>68</b>
<b>Unrestricted Elective Units</b>	<b>0</b>