



## DEGREE REQUIREMENT EVALUATION

ELM Satisfied	___	Yes	___	No
EPT Satisfied	___	Yes	___	No
GWT Satisfied	___	Yes	___	No

YEAR: 1997-98

California State Polytechnic University, Pomona

MAJOR **MECHANICAL ENGINEERING (5500)**  
 OPTION \_\_\_\_\_  
 UNITS REQUIRED 202

NAME \_\_\_\_\_  
LAST FIRST M.I.  
 STUDENT ID NO. \_\_\_\_\_

EVALUATOR \_\_\_\_\_  
 DATE \_\_\_\_\_  
 UPDATES \_\_\_\_\_

*Students in this major are expected to achieve and maintain a GPA of at least 2.00 in all courses included in Column I.*

A. GENERAL EDUCATION. Students may fulfill these requirements at Cal Poly Pomona with the General Education (GE) or the Interdisciplinary General Education (IGE) Programs. Select courses from approved lists shown in the Schedule of Classes unless specified.

Column I	Column II	Column IIIa	Column IIIb
<b>CORE COURSES IN MAJOR</b>	<b>Support and Directed Electives</b>	<b>Interdis. G.E.</b>	<b>AREA 1 – 12 units</b>
Mech Engr. Orient ME 100L 1	Gen Chem CHM 122 3	IGE 120 4	a) ENG 104 (4) b) COM 204 (4) c) <u>ME 231</u>
Engg Digital Comp ME 132/142L 3	Elem of Elec Engr ECE 231/251L 4	IGE 121 4	<b>AREA 2 – 16 units</b> (must include one lab course; area 2d must be upper division)
Vector Statics ME 214 3	Mfg. Sys. Processes MFE 201/211L 4	IGE 122 4	a) <u>MAT 114</u> (4) b) <u>CHM 121/L, 122L</u> (3,1,1)
Vector Statics Lab ME 214L 1	Engr. Graphics I MFE 126/L 3	IGE 220 4	c) Bio 110 (3) d) <u>ME 330</u> (4)
Vector Dynamics ME 215 4	Engr. Graphics II MFE 226/L 3	IGE 221 4	<b>AREA 3 – 24 units</b>
Strength Mtls ME 218 3		IGE 222 4	Arts, Literature, Philosophy, and Foreign Languages
Strength Mtls ME 219 3		IGE 223 4	a) Elective (4) b) Elective (4) c) UD or LD Elective (4)
Strength Mtls Lab ME 220L 1		IGE 224 4	Social, Political, and Economic Institutions
Engg Materials ME 225 4		IGE 225 4	d) EC 201 or 202 (4) e, f) PLS 390/SOC 390 (4)*
Intro to Mech Design ME 233/L 4		IGE 226 4	<b>AREA 4 – 8 units</b>
Thermodynamics ME 301 4		IGE 227 4	PLS 201 (4) and HST 202 (4)
Thermodynamics ME 302 4		IGE 228 4	<b>AREA 5 – 8 units</b> (A total of 12 upper division units required in GE—four in Area 2d and eight in Area 5.)
Fluid Mechanics ME 311 3		COM 204 4	<u>ECE 333/383L</u> (4), <u>EGR 403</u> (4)
Fluid Mechanics ME 312/313L 4		EC 201 4	*course satisfies two requirements
Intern. Vector Dynamics ME 316 3		or EC 202	<u>Underlined courses</u> satisfy both major and general education requirements.
Stress Analysis ME 319 4		<u>ME 231</u> 4	
Machine Design ME 325/L 4		Area 2-16 units (See Col IIIb)	
MtIs Design Lab ME 350L 1		Area 5-8 units (See Col IIIb)	
Heat Transfer ME 415 4			
Adv. Engr. Meas. ME 435/L 4			
Senior Project ME 461 2			
Senior Project ME 462 2			
Undergrad Seminar ME 463 2			
An Geom/Calculus II MAT 115 4			
An Geom/Calculus III MAT 116 4			
Calc of Sev Variables I MAT 214 3			
Calc of Sev Variables II MAT 215 3			
Diff Equations MAT 216 4			
General Physics PHY 131/151L 4			
General Physics PHY 132/152L 4			
General Physics PHY 133/153L 4			
*Technical Electives 19			
*Select from dept's list with advisor's approval.			
Column I Units Required 117	Column II Units Required 17	Column III Units Required 68	
		<b>TRANSFER ELECTIVES</b>	<b>SUMMARY OF ADVANCED STANDING CREDIT:</b>
			Earned Hours _____
			G.P.A. Hours _____
			Quality Points _____
			G.P.A. _____

NOT MORE THAN 105 UNITS FROM A COMMUNITY COLLEGE NOR MORE THAN 36 UNITS OF EXTENSION WORK MAY BE APPLIED TOWARD A BACHELOR'S DEGREE. ALL SPEAKERS OF ENGLISH AS A SECOND LANGUAGE WHO HAVE NOT ACHIEVED THE MINIMUM EPT SCORE FOR ENGLISH 104 MUST TAKE ENGLISH 102 AND 103.

A 2.0 CUMULATIVE GPA IS REQUIRED IN CORE COURSES INCLUDING OPTION COURSES IN ORDER TO RECEIVE A DEGREE IN THIS MAJOR. F-105-16 Rev. 2/97

**CALIFORNIA STATE POLYTECHNIC UNIVERSITY, POMONA  
MECHANICAL ENGINEERING DEPARTMENT**

1997-98

COURSE
P: Prerequisite C: Corequisite

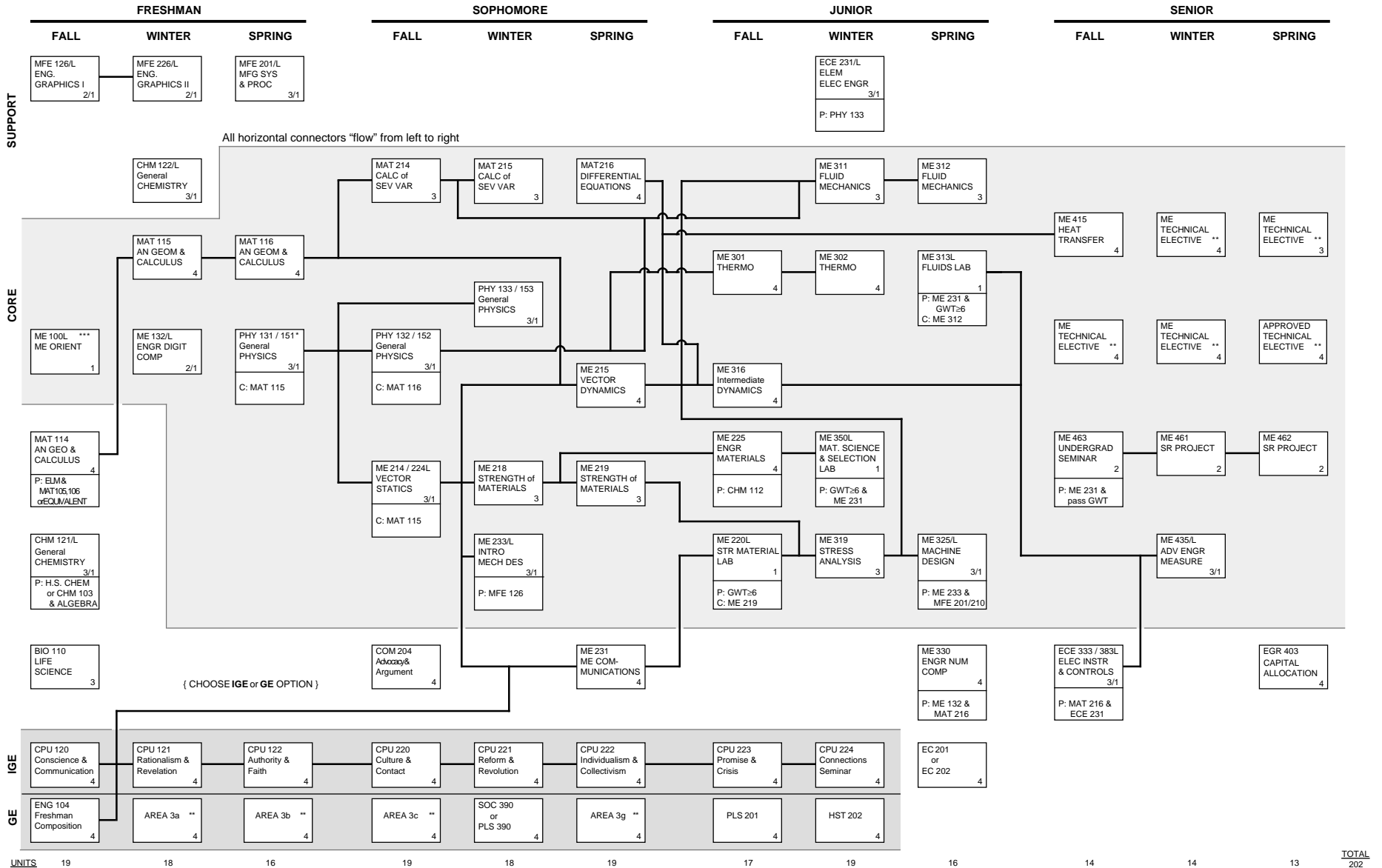

\* PHYSICS 131 SHOULD BE TAKEN NO LATER THAN SPRING QUARTER OF THE FRESHMAN YEAR  
 \*\* SEE LISTS OF APPROVED COURSES IN THESE AREAS  
 \*\*\* FRESHMAN AND TRANSFER STUDENTS SHOULD TAKE ME 100 DURING THE 1st FALL QUARTER AFTER ENTERING THE ME DEPARTMENT