

Audi > C5 Platform > 1998 - 2005**4.2 Liter V8 5V Engine Mechanical, Engine Code(s): ART, AWN, BBD
15 - Engine - Cylinder head, Valvetrain****Camshafts and camshaft adjusters, removing and installing****Removing**

- Remove toothed belt from camshaft sprockets => Page [13-19](#).
- Remove camshaft sprockets from cylinder bank 5-8.

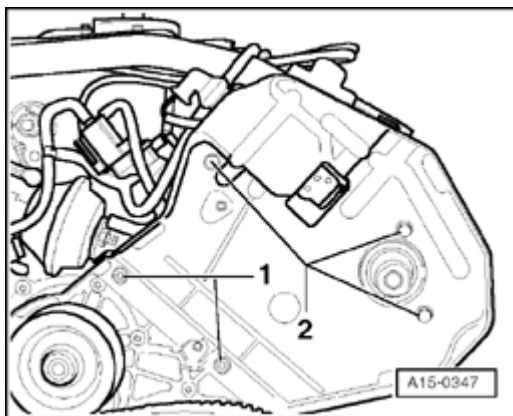

- Loosen bolts -1-.
- Remove bolts -2- and toothed belt cover.
- Remove cylinder head cover => Page [15-2](#).
- Remove Camshaft Position (CMP) sensor, item -30- and CMP rotor, item -27- => Page [15-35](#).

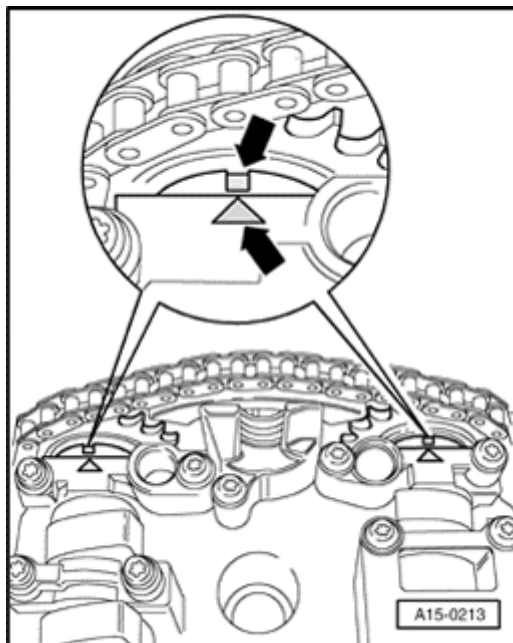

- Check TDC position of camshafts:

Both markings on camshafts must align with arrows on bearing caps.

When re-using drive chain:

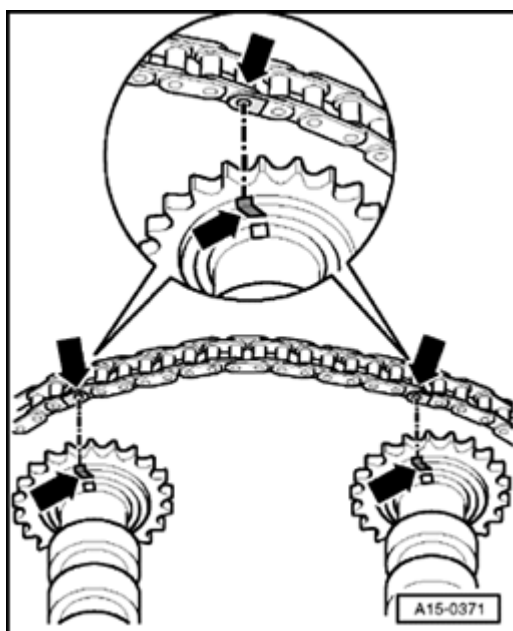

- Clean drive chain and camshaft sprockets. Mark position with paint.

CAUTION!

DO NOT mark chain with punch or scribe, use paint only.

Continuation

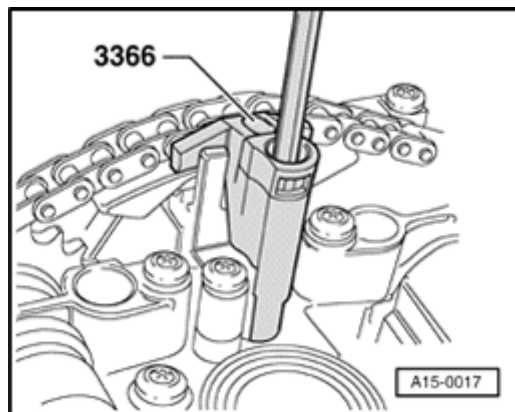

- Secure camshaft adjuster with bracket for chain tensioning tool 3366.

CAUTION!

Do not over-tighten bracket for chain tensioning tool, otherwise camshaft adjuster may be damaged

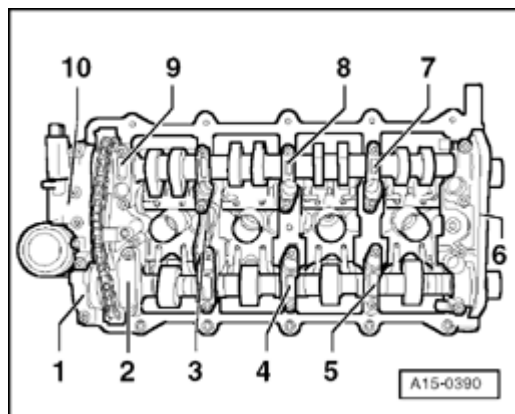

- Regardless of how bearing caps are marked, mark sequence and installation position of all bearing caps as shown in illustration.

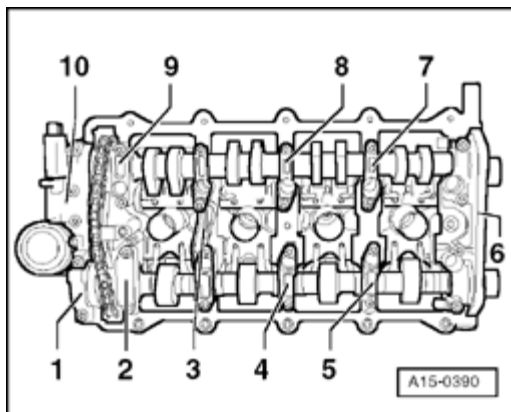

- Remove bolts for camshaft adjuster -arrow-.
- Remove bearing cap 0.
- Remove bearing caps 1, 3, 5, 7 and 8 and place in order on clean surface.
- Loosen bearing caps 2, 4, and 6 diagonally and remove.
- Remove camshafts with camshaft adjuster.

Installing

Install camshaft adjuster in reverse order of removal but note the following:

- Replace half-round cap.

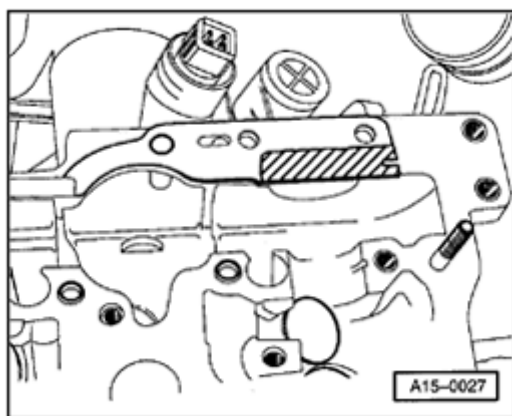

- Replace rubber-metal gasket for camshaft adjuster and coat the hatched area lightly with sealer AMV 100 001 02.

CAUTION!

Part numbers are listed for reference only. Always check with your Parts department for latest information.

- Place drive chain on camshaft sprockets as follows:

When using old chain:

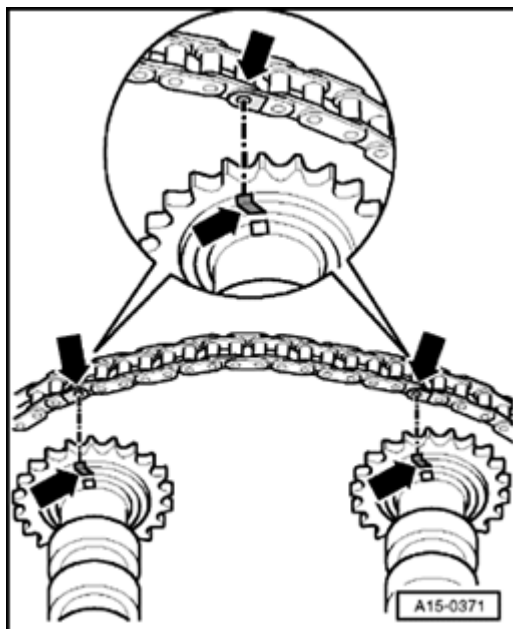

- Align paint markings -arrows-.

When using new drive chain:

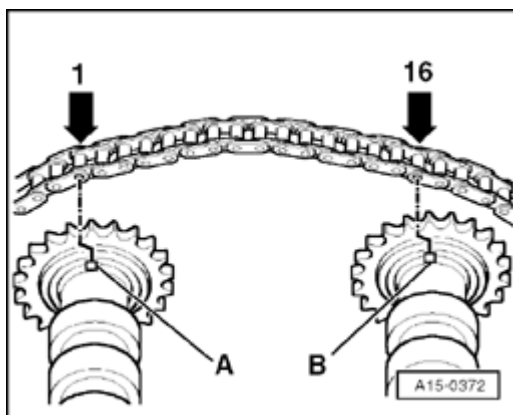

- ◆ The distance between camshaft markings -A- and -B- must be 16 rollers of the drive chain.
- Position rollers 1 and 16 according to illustration.
- ◆ Chain rollers 1 and 16 are offset by 1/2 tooth width to the left in relation to markings -A- and -B-.

Continuation

- Insert camshaft adjuster next to chain (requires second technician).

- Place camshafts with drive chain and camshaft adjuster into cylinder head.
- Lubricate running surfaces of camshafts with oil.

Note:

Be sure locating dowels for bearing caps and camshaft adjuster are installed in cylinder head.

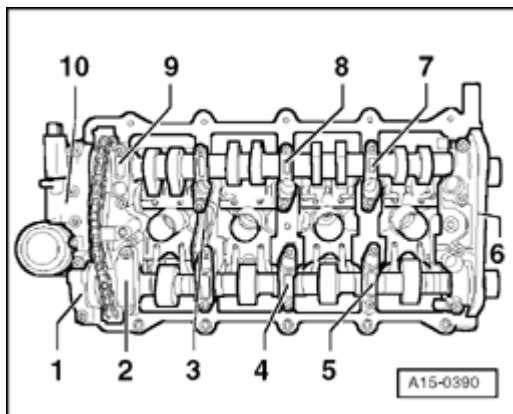

- Tighten camshaft adjuster (observe locating dowels).
- Install bearing caps 3, 5, and 7 according to markings.
- Tighten bearing caps 3, 5, and 7 of intake and exhaust camshafts diagonally (observe locating dowels).
- Install remaining bearing caps of intake and exhaust camshafts and tighten them from inside to outside in alternating diagonal sequence.
- Tighten camshaft adjuster -10- (pay attention to alignment bushings).
- Remove bracket for chain tensioner 3366.
- Check camshafts for correct adjustment.

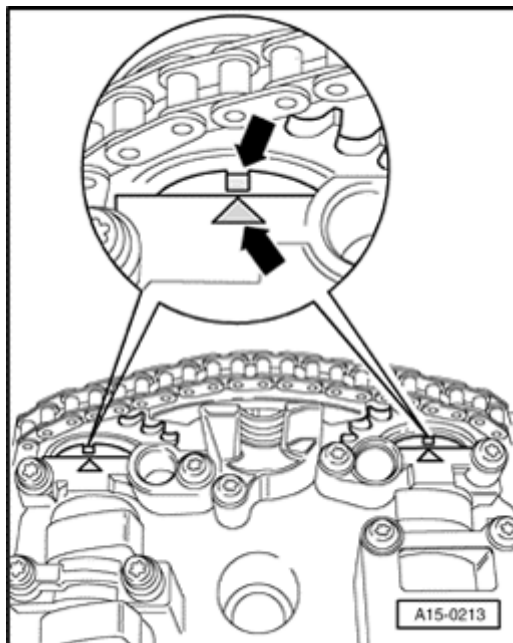

- Both markings at camshafts must align with markings on bearing caps -arrows-.

Note:

To make sure that alignment is correct, turn camshaft in direction of engine operation.

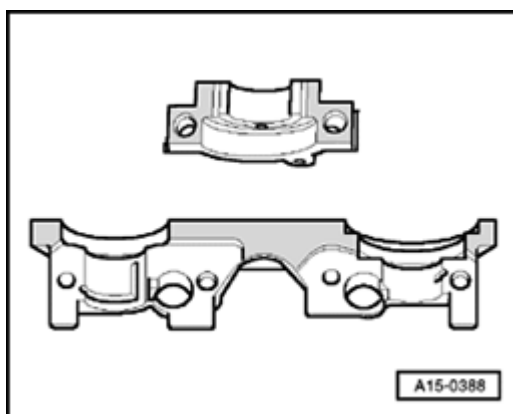

- Coat gray area of double bearing cap -6- and outer bearing cap -1- next to camshaft adjuster lightly with sealer AMV 100 001 02. Install bearing cap with camshaft seals (observe locating dowels).
- Install remaining bearing caps (observe locating dowels).

CAUTION!

Part numbers are listed for reference only. Always check with your Parts department for latest information.

- Tighten remaining bearing caps.

– Install toothed belt (adjust timing) => Page [13-13](#).

Note:

Observe all notes regarding removing and installing toothed belt => Page [13-6](#).

– Install cylinder head cover => Page [15-1](#).

Note:

- ♦ DO NOT immediately start engine after installing camshafts. Wait for at least 30 minutes, otherwise valves may hit pistons. The hydraulic lifters have to settle first.
- ♦ After completing work on the valve train, carefully turn crankshaft by hand for two revolutions to be sure that no valve contacts a piston.

Tightening torques

| Component | Nm |
|---|-------------------------|
| Bearing cap to cylinder head | 5 plus 1/4 turn (90 °) |
| Camshaft adjuster to cylinder head | 5 plus 1/4 turn (90 °) |
| Camshaft Position (CMP) sensor rotor to camshaft | 23 |
| Camshaft Position (CMP) sensor housing to cylinder head | 10 |

Valve stem seals, removing and installing

Special tools and equipment

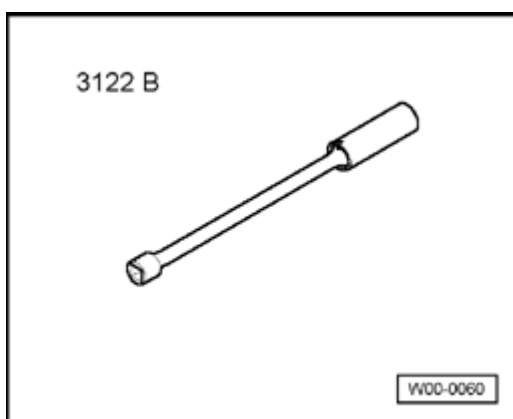

- ♦ Spark plug wrench 3122 B

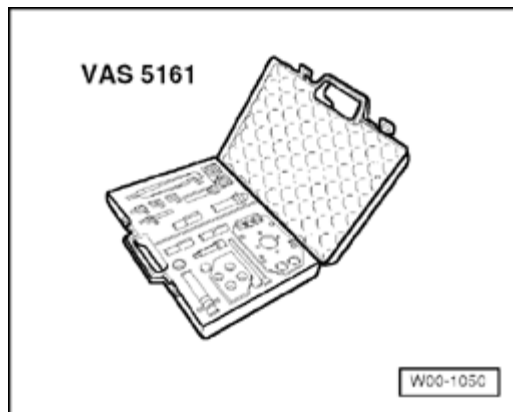

◆ Installation tool VAS 5161

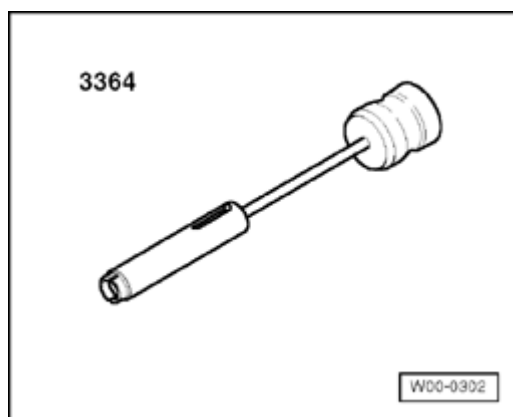

◆ Removal tool 3364

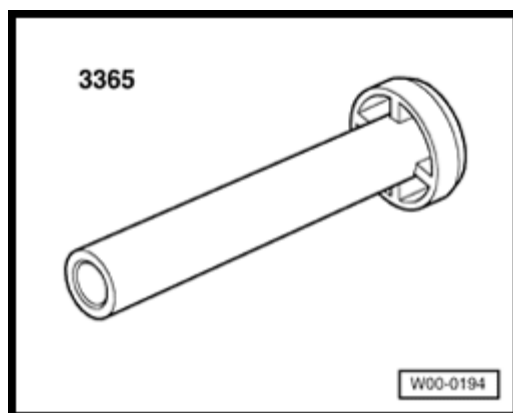

◆ Installation tool 3365

Removing

◆ Cylinder head installed

– Remove camshafts => Page [15-51](#).

- Remove spark plugs with spark plug wrench 3122B.

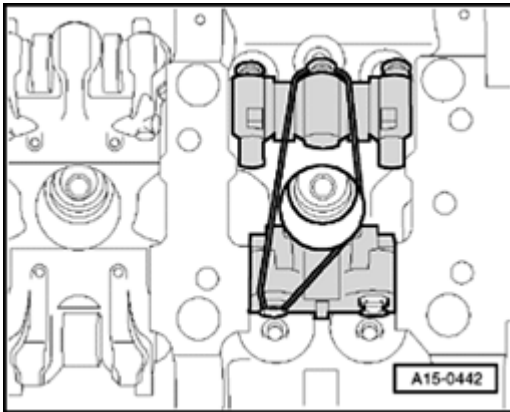

- Turn valve roller lever up and secure with rubber band.

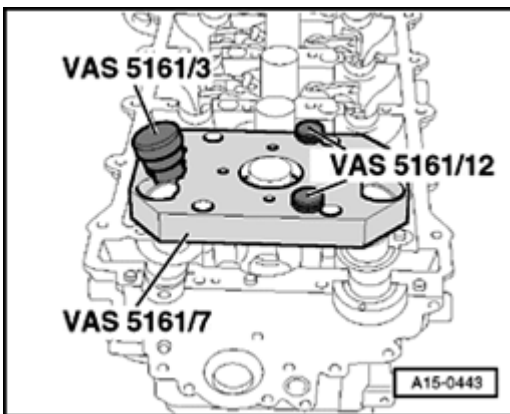

- Install mounting plate VAS 5161/7 from VAS 1561 to cylinder head.
- Secure plate with serrated screws VAS 5161/12.
- Using drift VAS 5161/3, loosen valve keepers by tapping with plastic hammer.

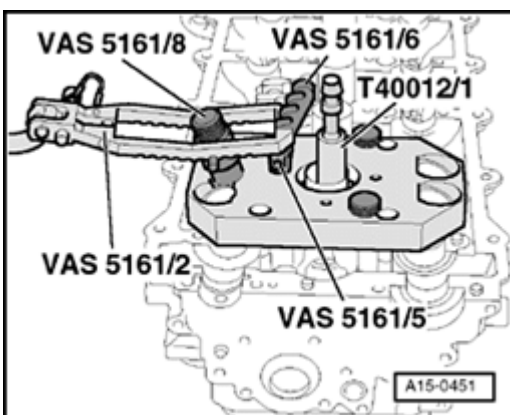

- Install serrated support VAS 5161/6 with VAS 5161/5 into plate 5161/7.

- Install cartridge VAS 5161/8 into plate VAS 5161/7.
- Install pressure hose adapter T40012/1 with sealing ring into applicable spark plug hole and hand tighten.
- Attach air hose and apply steady pressure.

Minimum air pressure 6 bar (87 psi)

- Insert lever VAS 5161/2 into lever support VAS 5161/6 and lightly press down on cartridge VAS 5161 / VAS 5161/8. Turn cartridge at serrated part until points engage in slots between valve keepers.

By slightly turning serrated part of cartridge, the valve keepers are separated and captured by the cartridge.

- Release pressure on lever.
- Remove valve spring and plate.

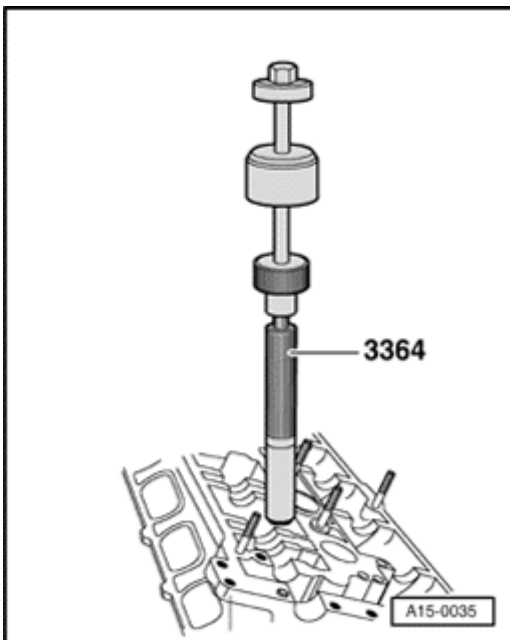

- Remove valve stem seal with 3364.

Installing

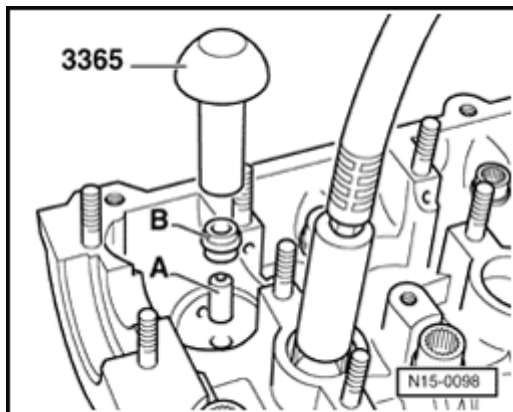

- To prevent damage to new seal, place plastic sleeve -A- on valve stem.
- Lightly lubricate sealing lip and valve stem with oil.
- Install valve stem seal -B- without oiling outside of seal, into seal driver 3129 and carefully push seal down over valve stem down to valve guide.

Valve guides, checking

Special tools and equipment:

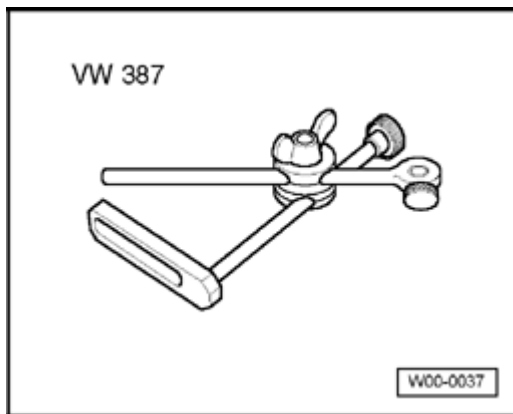

- ◆ Dial indicator bracket VW 387
- ◆ Dial indicator

CAUTION!

Because of the difference in stem diameters, always use an intake valve to check intake valve guides and only use an exhaust valve to check exhaust valve guides.

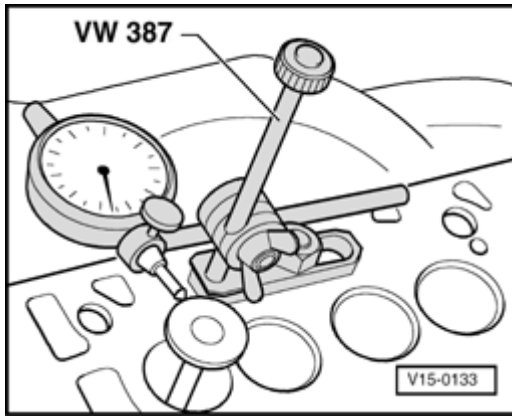

- Install valve in valve guide so that end of valve stem is flush with end of guide.
- Measure amount of rock (axial play).

Wear limit

| Intake valve guide | Exhaust valve guide |
|--------------------|---------------------|
| 0.8 mm (0.031 in.) | 0.8 mm (0.031 in.) |

Note:

- ◆ If the wear limit is exceeded, repeat measurement with new valves. If the measurement is again exceeded, replace cylinder head. Valve guides cannot be replaced.
- ◆ If you intend to replace the valve, measure with new valve.

Valves, checking

- Carefully check valve for wear at stem and seat. Replace valve when worn.

Valve seats, refacing

Special tools and equipment

- ◆ Depth gauge
- ◆ Valve lapping tool

Note:

- ◆ Repairing engines with leaking valves, especially engines with high mileage must include measuring valve guides => Page [15-66](#).
- ◆ Before refacing, calculate maximum permissible refacing dimension.
- ◆ If the maximum permissible refacing dimension is exceeded, the function of the hydraulic valve lifters can no longer be guaranteed and the cylinder head must be replaced.

- ◆ Reface valve seats just enough to produce a good seating pattern.

Maximum permissible refacing dimension, calculating

- Install valve and press it firmly onto the valve seat.

Note:

If valve is to be replaced, use new valve for measurement.

- Install valve and press firmly against valve seat.
- Measure distance between end of valve stem and top surface of cylinder head.
- Calculate maximum permissible refacing dimension from measured distance and minimum dimension.

Minimum dimensions

| Outer intake valve | Center intake valve | Exhaust valve |
|---------------------|---------------------|---------------------|
| 34.0 mm (1.338 in.) | 33.7 mm (1.326 in.) | 34.4 mm (1.354 in.) |

The measured distance minus the minimum dimension equals the maximum permissible refacing dimension.

Example:

Outer intake valve

| | |
|------------------------------|-----------------------|
| Measured distance | 34.4 mm (1.354 in.) |
| Minimum dimension | -34.0 mm (1.338 in.) |
| Maximum permissible refacing | = 0.4 mm (0.0157 in.) |

Note:

If the measured distance is less than the minimum dimension, repeat the measurement with new valves or replace the cylinder head.

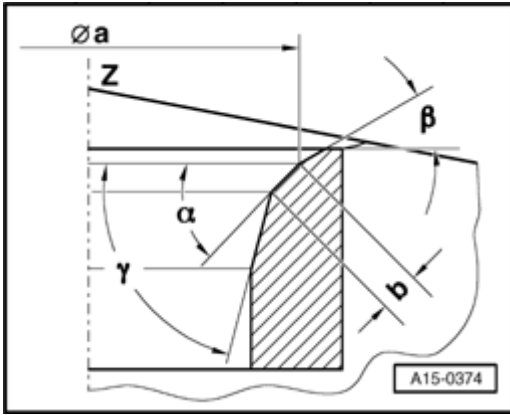

Valve seats, refacing

Intake valve seat:

$a = 26.2$ mm (1.0314 in.) diameter

$b = 1.5$ to 1.8 mm (0.059 to 0.070)

Z = Lower cylinder head surface

$\alpha = 45^\circ$ Valve seat angle

$\beta = 30^\circ$ Upper correction angle

$\gamma = 60^\circ$ Lower correction angle

Exhaust valve seat:

$a = 29.0$ mm (1.114 in.) diameter

$b = \text{approx. } 1.8$ mm (0.070)

Z = Lower cylinder head surface

$\alpha = 45^\circ$ Valve seat angle

$\beta = 30^\circ$ Upper correction angle

$\gamma = 60^\circ$ Lower correction angle