

ECE 109 - TIME-VARYING INPUTS - INVESTIGATION 27 BASIC PROPERTIES

SUMMER 2007

A.P. FELZER

To do "well" on this investigation you must not only get the right answers but must also do neat, complete and concise writeups that make obvious what each problem is, how you're solving the problem and what your answer is. You also need to include drawings of all circuits as well as appropriate graphs and tables.

The main objectives of this Investigation are to find Thevenin Equivalents of linear resistor circuits with time-varying inputs and to calculate energies. Be sure to take a look at the **Computer Demos** on Resistor Circuits With Sinusoidal Inputs.

1. We begin with superposition. Suppose we have the circuit

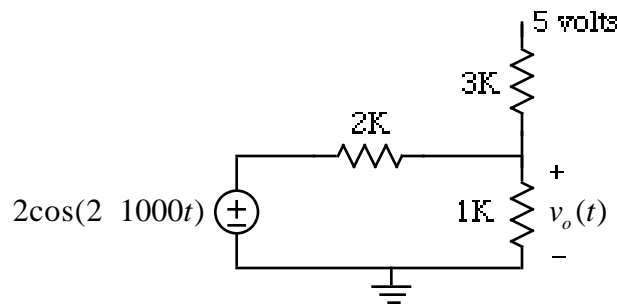

where the 5 volt source is connected from the top of the 3K resistor to the reference

- a. First find and sketch $v_o(t)$ without using superposition
- b. Then verify that superposition gives the same result

2. Given the following circuit

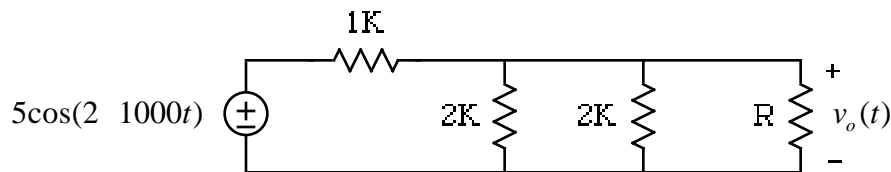

- a. Find and draw the Thevenin Equivalent as seen by R
- b. Find and sketch $v_o(t)$ when $R = 1K$

3. Now let's take a look at power, the rate at which energy is being transferred, in a circuit with a time-varying source like the following

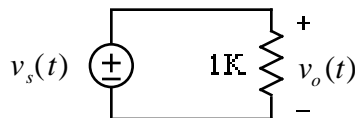

- a. Find and sketch $v_o(t)$ and the power $p(t) = v_o^2(t)/R$ for the resistor if $v_s(t)$ is

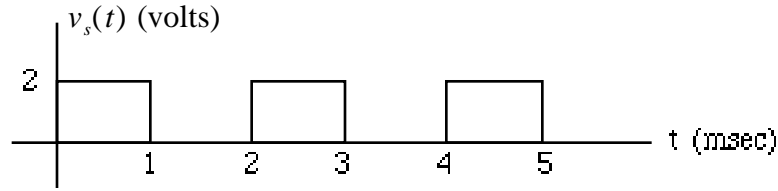

b. Find and sketch $v_o(t)$ and the power $p(t) = v_o^2(t)/R$ for the resistor if $v_s(t)$ is

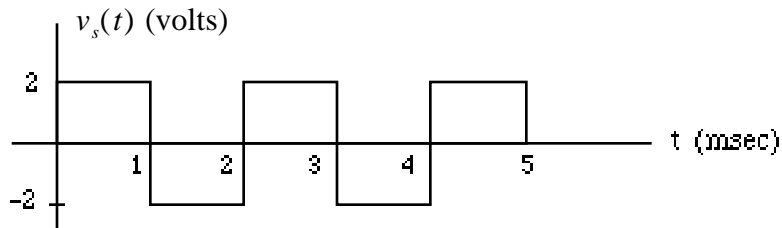

- c. Find and sketch $v_o(t)$ and the power $p(t) = v_o^2(t)/R$ for the resistor if $v_s(t) = 5\cos(2000t)$. Remember that $\cos^2(x) = 0.5 + 0.5\cos(2x)$
- d. So far we've been finding that $p(t) = 0$ for all t for resistor circuits. Why did this happen. What does it mean. Would you expect the same thing to happen in a more general linear resistor circuit like the following

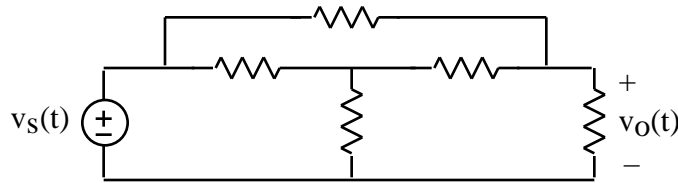

Why

4. Up to now we've only been calculating energies when the power is constant like the following

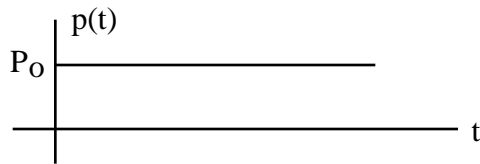

in which case the energy transferred in **T seconds** when P_o is in **watts** is simply

$$E(T) = P_o T$$

But to calculate energies when the power varies with time like this

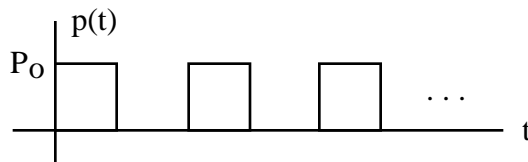

we have to go back to basics

a. From physics we know that

$$p(t) = \frac{dE(t)}{dt}$$

Describe in words this relationship between power and energy

b. Solving for $E(t)$ in part (a) we have

$$E(t) = \int_0^t p(t) dt$$

Make use of this expression to calculate the energy transferred to a resistor in 4 msec if $p(t)$ is given by

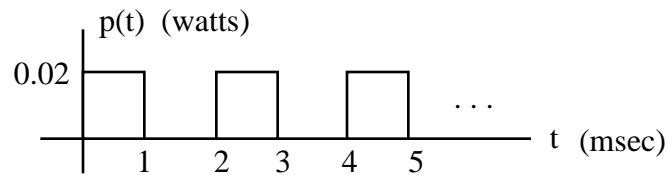

c. Calculate the energy transferred to a $R = 2K$ resistor in 4 seconds if $p(t)$ is the same as part (c) of Problem (3)

d. Calculate the energy transferred to a $R = 2K$ resistor in 2 seconds if $v(t) = 5\cos(200t)$

5. Math Review: What is the frequency in cycles/sec of $x(t) = \cos(200t) + \cos(300t)$