

## ECE 109 - NODE ANALYSIS - INVESTIGATION 16 PRACTICE WITH NODE EQUATIONS

SUMMER 2007

A.P. FELZER

To do "well" on this investigation you must not only get the right answers but must also do neat, complete and concise writeups that make obvious what each problem is, how you're solving the problem and what your answer is. You also need to include drawings of all circuits as well as appropriate graphs and tables.

We have from the previous investigation the following scheme for analyzing resistor circuits -

- (1) Write and solve the node equations for the node voltages
- (2) Make use of the node voltages to calculate the voltages across and the currents through the resistors
- (3) Make use of the resistor currents to calculate the currents through the voltage sources

The objective of this Investigation is to get some practice writing and solving node equations. As you can imagine, it's very important to keep your equations carefully organized. *So from this point on and forever after you must label every node equation with the node that it's for and put your node equations in matrix form.* Be sure to take a look at the **Computer Demos** on Node Equations.

1. Make use of node equations to find  $V_O$  in the following circuit

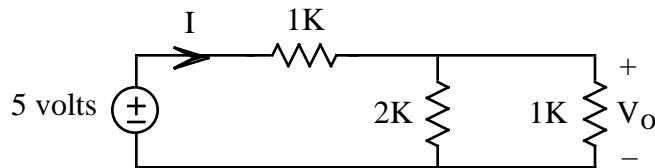

And then make use of your result for  $V_O$  to calculate  $I$

2. Make use of node equations to find  $V_O$  in the following circuit and then make use of your result for  $V_O$  to find  $I$

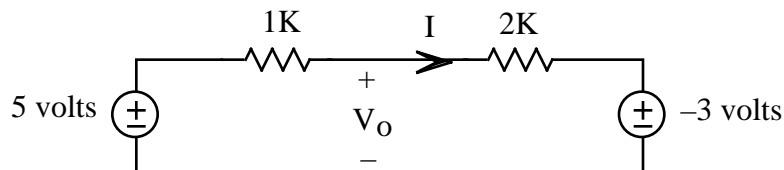

3. Make use of node equations to find  $V_1$  and  $V_2$  in the following circuit

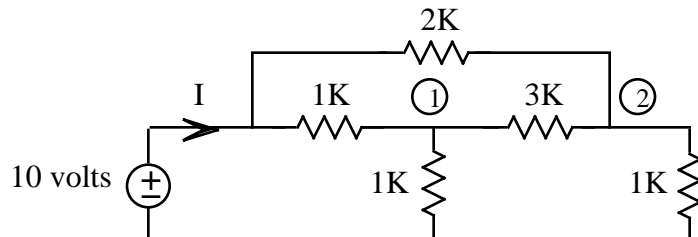

and then make use of your results for  $V_1$  and  $V_2$  to calculate  $I$

4. Make use of node equations to find  $V_A$ ,  $V_B$  and  $V_C$  in the following circuit

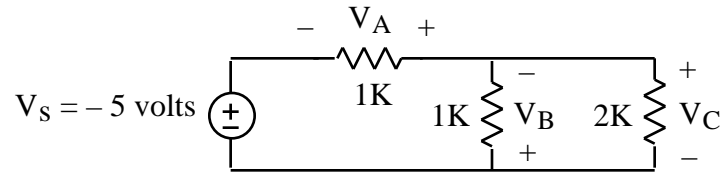

5. Make use of node equations to find the *voltage division equation* for  $V_2$  in the following series circuit

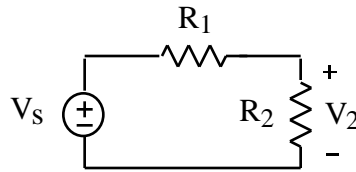

6. Make use of node equations to find the *current division equation* for  $I_2$  in the following parallel circuit

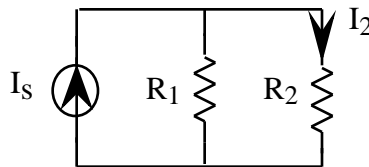

7. Make use of node equations to find  $V_1$  in the following circuit

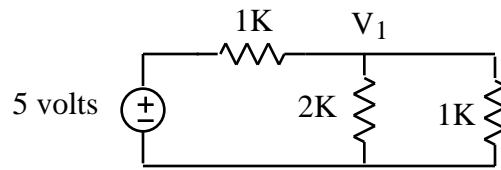

and then make use of your result to find the power for the 2K resistor

8. The **open circuit voltage drop** at the output of a circuit like the following

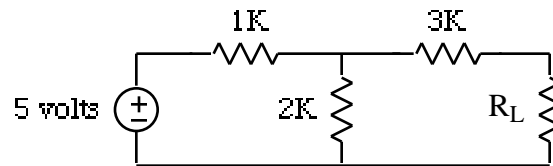

is by **definition** the voltage drop  $V_{oc}$  when the load  $R_L$  is removed as follows

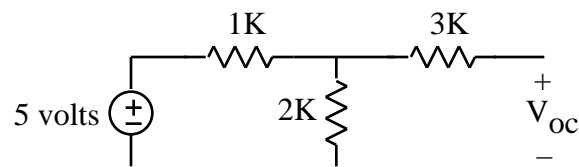

- a. Why do you think we call an open circuit voltage drop an open circuit voltage drop
- b. Explain why  $V_{OC}$  in our circuit is equal to the voltage drop  $V_1$  across the 2K resistor as follows

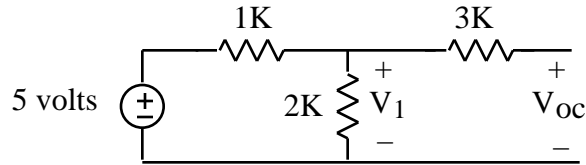

- c. Make use of node equations to find  $V_{OC}$

9. Given the following circuit

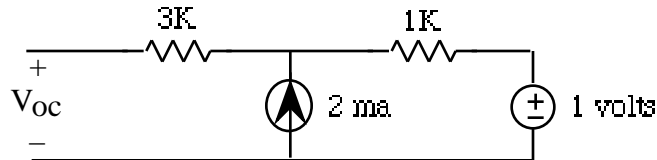

- a. Make use of node equations to find the open circuit voltage  $V_{OC}$
- b. Now make use of node equations to find  $I$  in the following circuit with  $V_{OC}$  equal to the open circuit voltage found in part (a)

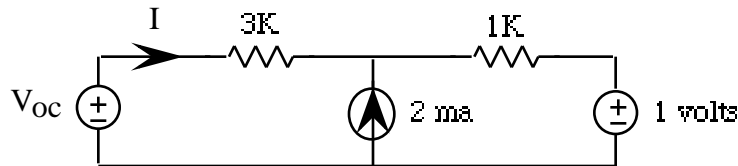

10. Generalizing on the result of Problem (9) it can be shown that if  $I = 0$  in a circuit as follows

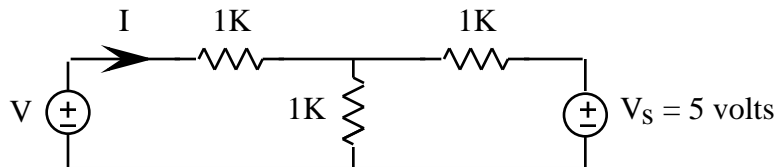

then  $V = V_{OC}$ . **Memorize** this result. Then confirm it for this circuit.

11. Use node equations to find  $V_1$  and  $V_2$  in the following circuit

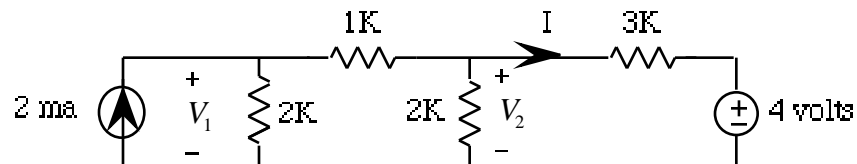

and then make use of your results to calculate  $I$

12. Find  $I$  as a function of  $V_S$  in the following circuit if  $V_1 = 0.7 V_S$

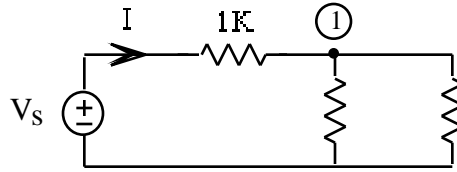

13. Given the following circuit

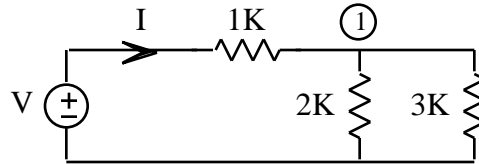

- a. First make use of node equations to find  $V_1$  as a function of  $V$
- b. Then make use of your result in part (a) to find  $I$  as a function of  $V$

14. Explain how you would make use of node analysis to find  $I$  as a function of  $V_s$  in the following circuit

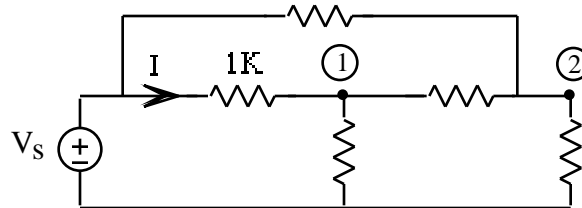

15. Find  $I$  and  $I_1$  in the following circuit. But beware - node equations are not always the best.

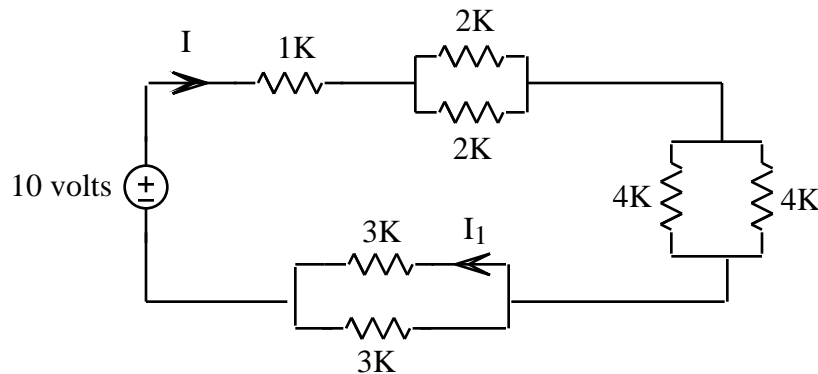

16. Math Review: Given the following two points in the  $xy$ -plane:  $P_1 = (2, 3)$  and  $P_2 = (-1, 4)$ 
  - a. Sketch the points in the plane
  - b. Find the distance between them