

# ECE 109L - THE VERY BASICS - LAB 8

## KIRCHHOFF'S VOLTAGE LAW

SUMMER 2007

A.P. FELZER

### OBJECTIVE

The objective of this lab is to verify Kirchhoff's Voltage Law for some simple resistor circuits.

### LAB

1. Put together the following circuit on your resistor box

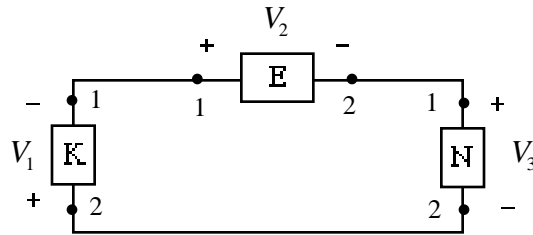

- a. **PreLab** - What do we need to measure to determine the direction the epc is flowing
  - b. Make the measurement specified in part (a)
  - c. Make use of your result in part (b) to determine the direction the epc is flowing
  - d. **PreLab** - redraw the circuit with voltmeters connected for measuring  $V_1$ ,  $V_2$  and  $V_3$
  - e. Measure  $V_1$ ,  $V_2$  and  $V_3$
  - f. Explain how knowing the direction *equivalent positive charges* (epc) are flowing through a circuit element together with knowing whether they're going from a higher to a lower potential or a lower to a higher potential can be used to determine whether the epc are delivering energy to the circuit element or receiving energy from it.
  - g. Make use of your results to determine which circuit elements are transferring energy to the epc and which receiving energy from them. Put your results in a Table
  - h. Add up those voltages where the epc are receiving energy from the circuit elements
  - i. Add up those voltages where the epc are transferring energy to the circuit elements
  - j. Make use of your results in parts (h) and (i) to verify that the equivalent positive charges flowing all the way around the loop return with the same amount of potential energy as when they started
2. What's the underlying physical reason why the sum of the voltages around a closed loop is equal to zero when the reference directions are aligned as follows

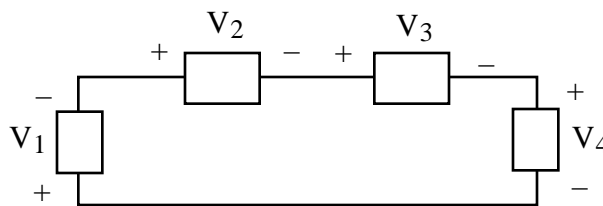

3. The objective of this problem is to verify that Kirchhoff's Voltage Law is satisfied for the following circuit - that the *algebraic sum* of the voltages around the closed loop is equal to zero

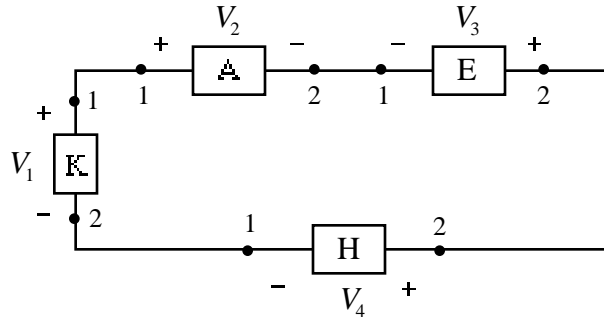

- a. Write KVL
- b. Measure the voltages
- c. Verify that KVL is satisfied